

# 10 SERIES

# 1/4"-2"

**UNIBODY, SCREWED END, 2000 WOG  
DOUBLE REDUCED PORT  
BALL VALVE  
API-607 FIRESAFE 4th Ed.**

FED. SPEC. WW-V-35C, II, Style 3  
MSS SP-110

- Sizes 1/4"-2"
- Pressure Rating 2000 WOG / 150 WSP
- Temperature Range -20 to 450°F.
- Body Material WCB or CF8M.
- Body materials meet **ASTM** specifications.
- RPTFE Seats Standard.
- One Piece Investment Cast Body
- Valves are **API 607 Fire-Safe** and include graphite stem-packing.
- All valves are tested in accordance with latest **ASME B16.34 specifications**.
- Blow-out Proof Stem
- Low Torque Seats
- Standard Locking Handle

## MATERIALS LIST

ITEM	PART	MODEL	MATERIALS	MAT. SPEC.
1	Body	10CSOD-02-LL	Carbon Steel	A 216-WCB
		10SSOD-02-LL	Stainless Steel	A 351-CF8M
2	Ball Retainer	10CSOD-02-LL	Carbon Steel	A 216-WCB
		10SSOD-02-LL	Stainless Steel	A 351-CF8M
3	Ball	10CSOD-02-LL	Stainless Steel	316 SS
		10SSOD-02-LL	Stainless Steel	316 SS
4	Stem	10CSOD-02-LL	Stainless Steel	316 SS
		10SSOD-02-LL	Stainless Steel	316 SS
5	Seat	10CSOD-02-LL	RTFE	-
		10SSOD-02-LL	RTFE	-
6	Thrust Washer	10CSOD-02-LL	RTFE	-
		10SSOD-02-LL	RTFE	-
7	Stem Packing	10CSOD-02-LL	GRAPHOIL	-
		10SSOD-02-LL	GRAPHOIL	-
8	Gland	10CSOD-02-LL	Carbon Steel	A 283 CS
		10SSOD-02-LL	Stainless Steel	316 SS
9	Handle	10CSOD-02-LL	Carbon Steel	A 283 CS
		10SSOD-02-LL	Stainless Steel	304 SS
10	Handle Nut	10CSOD-02-LL	Carbon Steel	A 283 CS
		10SSOD-02-LL	Stainless Steel	304 SS

10SERM.TLS.xls

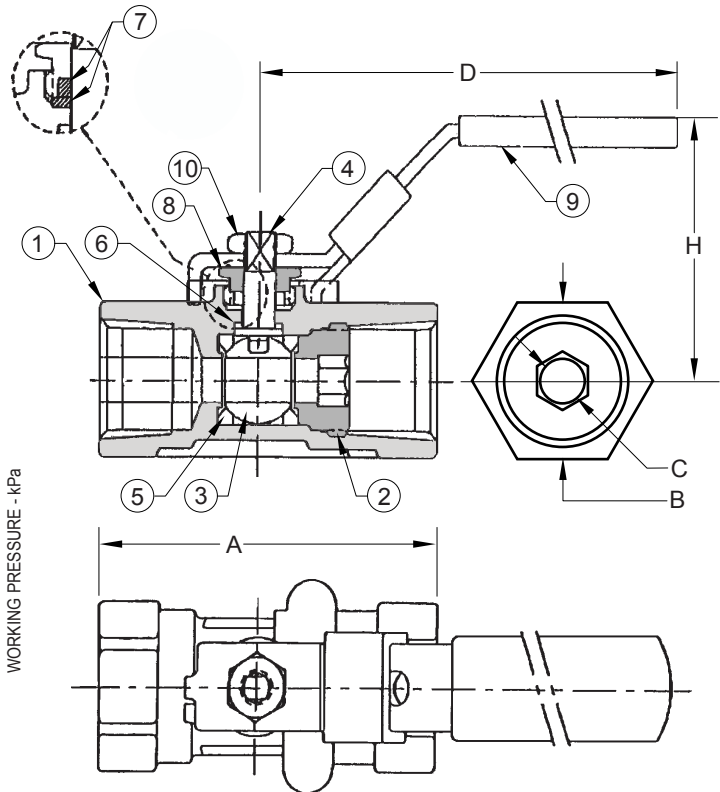

## PRESSURE - TEMPERATURE DATA

VALVES RATED FOR VACUUM SERVICE TO 29 INCHES Hg.

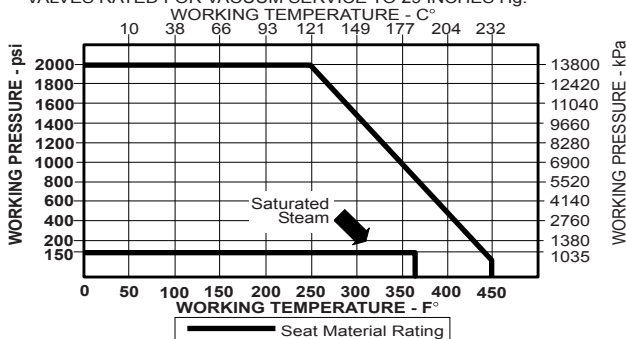

## DIMENSIONS

	UNITS	1/4"	3/8"	1/2"	3/4"	1"	1-1/4"	1-1/2"	2"
		DN6	DN10	DN15	DN20	DN25	DN32	DN40	DN50
A	INCHES	2.28	2.28	2.60	2.83	3.23	3.54	3.86	4.33
	mm	57.9	57.9	66.0	71.9	82.0	89.9	98.0	110.0
B	INCHES	1.10	1.10	1.10	1.34	1.61	1.97	2.24	2.76
	mm	27.9	27.9	27.9	34.0	40.9	50.0	56.9	70.1
C	INCHES	0.31	0.31	0.31	0.48	0.63	0.81	1.00	1.25
	mm	7.9	7.9	7.9	12.2	16.0	20.6	25.4	31.8
D	INCHES	4.17	4.17	4.17	4.17	5.71	5.71	7.24	7.24
	mm	105.9	105.9	105.9	105.9	145.0	145.0	183.9	183.9
H	INCHES	1.97	1.97	1.97	2.20	2.56	2.76	3.29	3.49
	mm	50.0	50.0	50.0	55.9	65.0	70.1	83.6	88.6
F	THREAD SIZE	1/4" NPT	3/8" NPT	1/2" NPT	3/4" NPT	1" NPT	1-1/4" NPT	1-1/2" NPT	2" NPT
Cv		3	4	5	9	14	22	50	81

Note: DN (Diameter Nominal) = Metric equivalent size.

10SERDIM.xls

Rev. 3

The information presented on this sheet is correct at the time of publication. Milwaukee Valve reserves the right to change design, and/or material specifications without notice. For the most current information access [www.milwaukeevalve.com](http://www.milwaukeevalve.com)

MILWAUKEE VALVE

