

# GLOBE 1590T BRONZE

150 lb. SWP-300 lb. WOG† • Heavy Duty Service  
Teflon Disc • Union Bonnet • Gland Packed • Sweat Ends

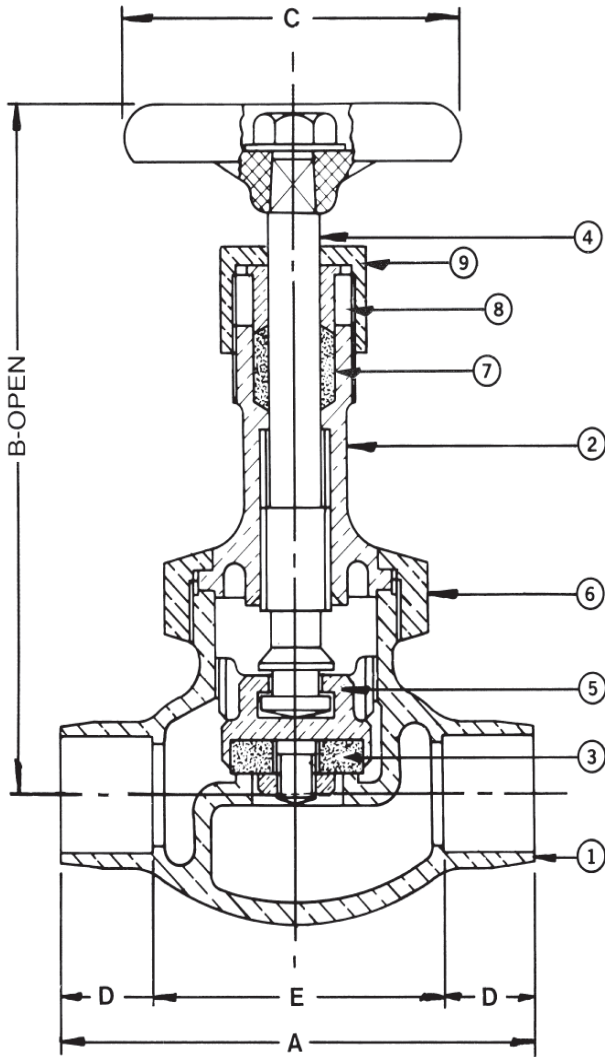

## SPECIFICATIONS

1590T	Conforms to: MSS SP-80. Type 2, Class 150, Soldered Ends.
-------	--

## MATERIAL LIST

NO.	PART	MATERIAL	SPECIFICATION
1	Body	Bronze	ASTM B 62
2	Bonnet	Bronze	ASTM B 62
3	Disc	Teflon	
4	Stem	Bronze	ASTM B 62
5	Disc Holder	Bronze	ASTM B 62
6	Union Bonnet Nut	Bronze	ASTM B 62
7	Packing	Graphite	Commercial
8	Gland	Brass	ASTM B 16
9	Packing Nut	Bronze	ASTM B 584
10	Disc Nut	Bronze	ASTM B 62
11	Handwheel	Malleable Iron	Commercial
12	Identification Plate	Aluminum	Commercial
13	Handwheel Nut	Brass	ASTM B 16

## DIMENSIONS - INCHES / MILLIMETERS

Units	Size	A	B	C	D	E	C <sub>v</sub>
Inches	1/2	2.75	4.50	2.25	0.50	1.75	3.64
mm	12.7	69.9	114.3	57.2	12.7	44.5	
Inches	3/4	3.56	5.19	2.75	0.75	2.06	6.65
mm	19.1	90.5	131.8	69.9	19.1	52.4	
Inches	1	4.31	5.50	3.13	0.91	2.50	11.10
mm	25.4	109.6	139.7	79.4	23.0	63.5	
Inches	1 1/4	5.00	6.25	3.50	0.97	3.06	20.00
mm	31.8	127.0	158.8	88.9	24.6	77.8	
Inches	1 1/2	5.75	7.13	3.75	1.09	3.56	28.00
mm	38.1	146.1	181.0	95.3	27.8	90.5	
Inches	2	7.06	8.88	4.75	1.34	4.38	48.00
mm	50.8	179.4	225.4	120.7	34.1	111.1	
Inches	2 1/2	8.19	10.63	5.50	1.47	5.25	70.00
mm	63.5	208.0	269.9	139.7	37.3	133.4	
Inches	3	9.56	12.13	6.00	1.66	6.25	111.00
mm	76.2	242.9	308.0	152.4	42.0	158.8	

† Non-Shock

Rev. 7

**INNOVATION** IN EVERY VALVE



**MILWAUKEE VALVE**

The information presented on this sheet is correct at the time of publication. Milwaukee Valve reserves the right to change design, and/or material specifications without notice. For the Installation, Operation and Maintenance Manual (IOM) see the engineering section on our website. For the most current information access [www.milwaukeevalve.com](http://www.milwaukeevalve.com)

[www.milwaukeevalve.com](http://www.milwaukeevalve.com)

Printed on recycled paper with soy ink. 05/05