

ANGLE 595T BRONZE

150 lb. SWP-300 lb. WOG† • Heavy Duty Service
Teflon Disc • Union Bonnet • Gland Packed • Threaded Ends

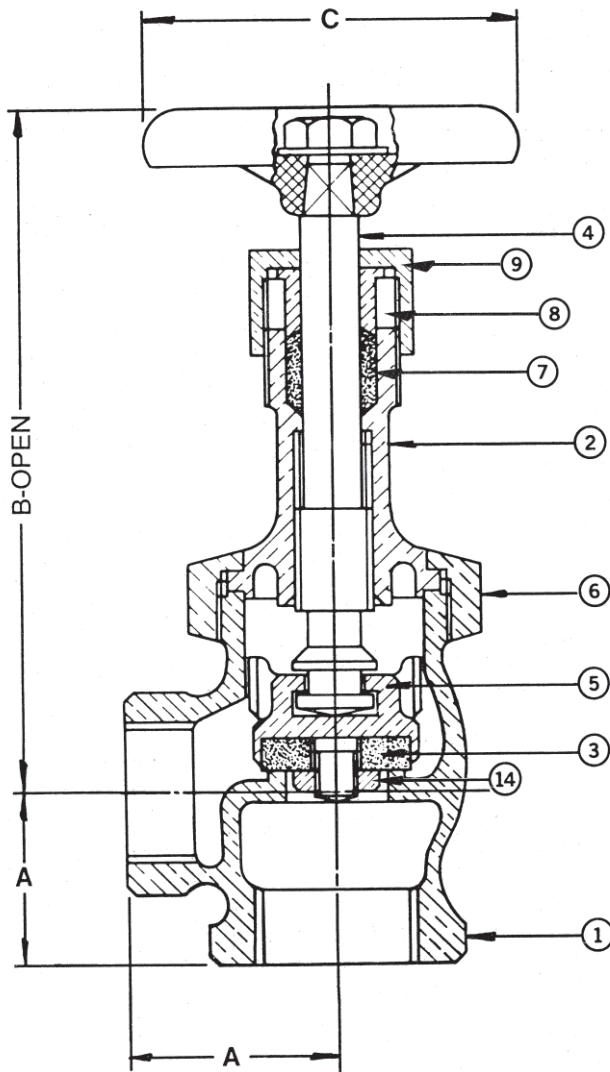

SPECIFICATIONS

595T	Conforms to: MSS SP-80. Type 2, Class 150, Threaded Ends.		
MATERIAL LIST			
NO.	PART	MATERIAL	SPECIFICATION
1	Body	Bronze	ASTM B 62
2	Bonnet	Bronze	ASTM B 62
3	Disc	Teflon	
4	Stem	Bronze	ASTM B 62
5	Disc Holder	Bronze	ASTM B 16 1/4" to 3/4" ASTM B 62 1" to 3" Incl.
6	Union Bonnet Nut	Bronze	ASTM B 62
7	Packing	Graphite	Commercial
8	Gland	Bronze	ASTM B 16
9	Packing Nut	Bronze	Commercial
10	Disc Nut	Bronze	Commercial
11	Handwheel	Mall. Iron	Commercial
12	Identification Plate	Aluminum	Commercial
13	Handwheel Nut	Bronze	Commercial
14	Disc Nut	Brass	ASTM B 16

DIMENSIONS - INCHES / MILLIMETERS

Units	Size	A	B	C	C _v
Inches	1/4	1.06	3.94	2.00	1.60
mm	6.4	27.0	100.0	50.8	
Inches	3/8	1.19	4.25	2.00	3.10
mm	9.5	30.2	108.0	50.8	
Inches	1/2	1.19	5.13	2.50	5.10
mm	12.7	30.2	130.2	63.5	
Inches	3/4	1.44	5.19	2.75	9.20
mm	19.1	36.5	131.8	69.9	
Inches	1	1.75	6.56	3.13	16.00
mm	25.4	44.5	166.7	79.4	
Inches	1 1/4	2.06	6.25	3.50	28.00
mm	31.8	52.4	158.8	88.9	
Inches	1 1/2	2.25	7.63	4.00	39.00
mm	38.1	57.2	193.7	101.6	
Inches	2	2.75	8.88	4.75	66.00
mm	50.8	69.9	225.4	120.7	

† Non-Shock

Rev. 5

INNOVATION IN EVERY VALVE



MILWAUKEE VALVE

www.milwaukeevalve.com

The information presented on this sheet is correct at the time of publication. Milwaukee Valve reserves the right to change design, and/or material specifications without notice. For the Installation, Operation and Maintenance Manual (IOM) see the engineering section on our website. For the most current information access www.milwaukeevalve.com