

# BA-100-M

# 1/4" - 2"

**BRONZE BALL VALVE**  
**TWO-PIECE, STANDARD-PORT**  
**600 PSIG WOG / 150 PSIG SWP \***  
**FNPT x MNPT CONNECTIONS**

MSS SP-110

## MATERIALS LIST

ITEM	PART	MATERIALS	ASTM SPEC.
1	Body	Cast Bronze	B584
2	Tailpiece	Brass / Bronze (1" & up)	B16 / B584
3	Ball	Brass w/ Hard Chrome Plating	B16
4	Seat	RPTFE, 15% Glass Filled	
5	Stem	Brass	B16
6	Thrust Washer	RPTFE, 15% Glass Filled	
7	Packing	PTFE	
8	Packing Nut	Brass	B16
9	Handle	Steel w/ Zinc Plating	Commercial
10	Hand Grip	Vinyl	
11	Handle Nut	Steel w/ Zinc Plating	Commercial

Please consult factory for more information regarding steam applications.

## PRESSURE - TEMPERATURE CHART

VALVES RATED FOR VACUUM SERVICE TO 29 INCHES Hg.

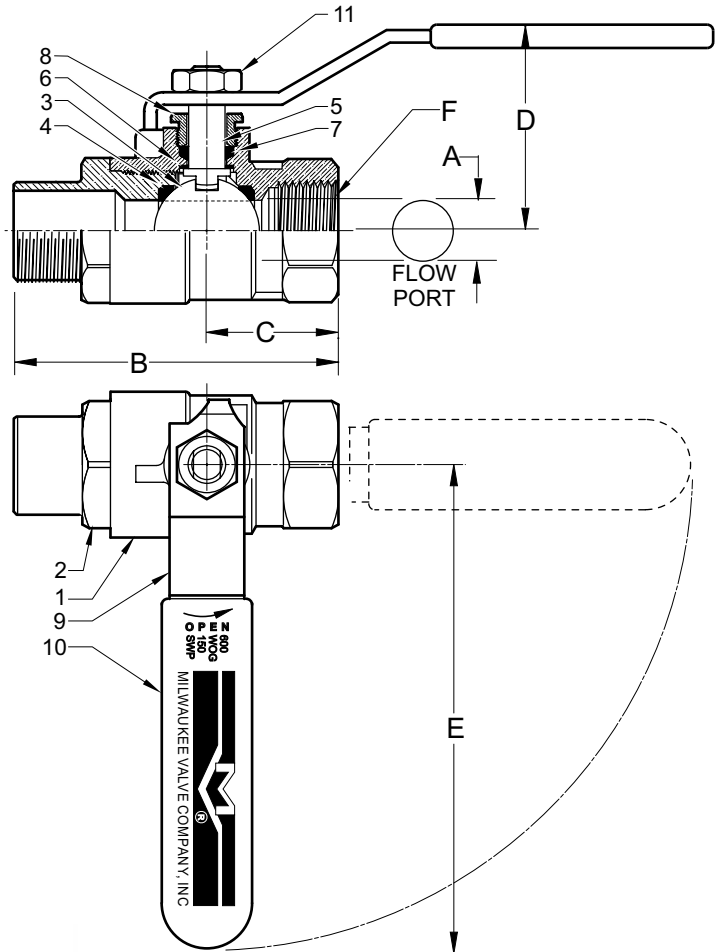
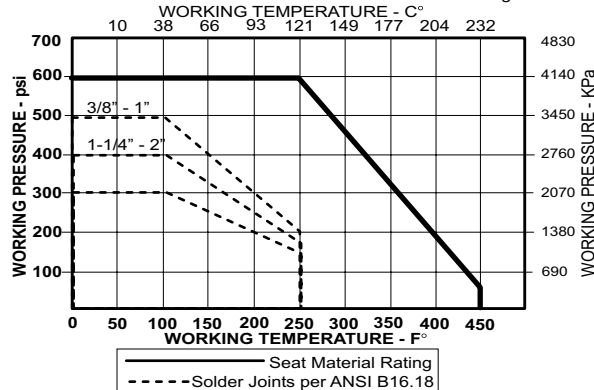

## DIMENSIONS

	UNITS	1/4"	3/8"	1/2"	3/4"	1"	1-1/4"	1-1/2"	2"
A (DIA)	INCHES	0.38	0.38	.50	0.76	0.88	1.06	1.31	1.56
	mm	9.7	9.7	12.7	19.3	22.4	26.9	33.3	39.6
B	INCHES	2.50	2.50	2.82	3.03	3.63	4.25	4.69	4.94
	mm	73.9	89.7	101.6	73.9	89.7	101.6	113.3	133.9
C	INCHES	1.30	1.58	1.74	1.30	1.58	1.74	1.97	2.15
	mm	33.0	40.0	44.0	33.0	40.0	44.0	50.0	55.0
D	INCHES	2.08	2.25	2.66	2.08	2.25	2.66	2.84	3.00
	mm	53.0	57.0	67.0	53.0	57.0	67.0	72.0	76.0
E	INCHES	4.84	4.84	6.35	4.84	4.84	6.35	6.35	7.20
	mm	123.0	123.0	161.0	123.0	123.0	161.0	161.0	183.0
F	THREAD SIZE	1/4" NPT	3/8" NPT	1/2" NPT	3/4" NPT	1" NPT	1-1/4" NPT	1-1/2" NPT	2" NPT
	Cv	11	11	17	30	40	52	90	115

Note: DN (Diameter Nominal) = Metric equivalent size.

Rev. 5

The information presented on this sheet is correct at the time of publication. Milwaukee Valve reserves the right to change design, and/or material specifications without notice. For the most current information access [www.milwaukeevalve.com](http://www.milwaukeevalve.com)

