

BA-250

3/8"-3"

**FORGED BRASS BALL VALVE
TWO PIECE, STANDARD PORT
400 PSIG WOG / 150 PSIG SWP *
SOLDER ENDS**

NSF61-8
ASME A112.4.14

MSS-SP110



MATERIALS LIST

ITEM	PART	MATERIALS	ASTM SPEC.
1	Body	Brass, Forged	B283
2	Tailpiece	Brass, Forged	B283
3	Ball	Brass	B16
		Brass, Cast	B584
4	Seat	PTFE	
5	Stem	Brass	B16
6	Thrust Washer	PTFE	
7	Gland Nut	Brass	B16
8	Gland Packing	PTFE	
9	Handle	Steel w/ Zinc Plating	Commercial
10	Handle Nut	Brass	B16

* Please consult factory for more information regarding steam applications.

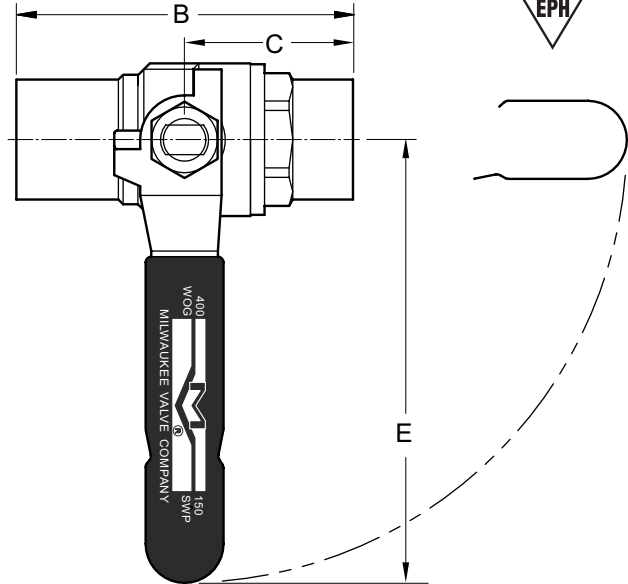

PRESSURE - TEMPERATURE DATA

VALVES RATED FOR VACUUM SERVICE TO 29 INCHES Hg.

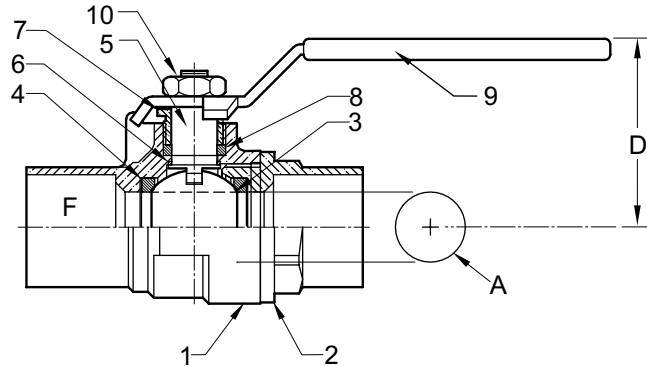
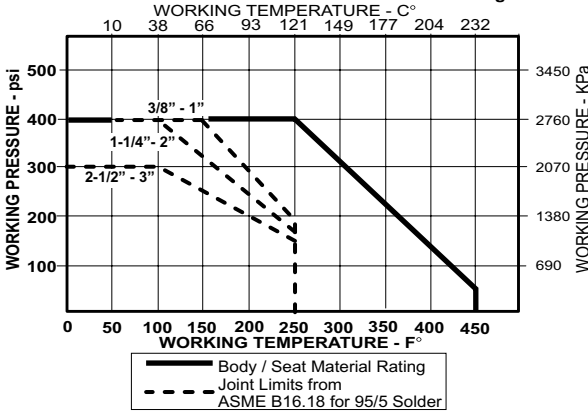

DIMENSIONS

	UNITS	3/8"	1/2"	3/4"	1"	1-1/4"	1-1/2"	2"	2-1/2"	3"
		DN10	DN15	DN20	DN25	DN32	DN40	DN50	DN65	DN80
A (DIA)	INCHES	0.31	0.39	0.59	0.76	0.98	1.26	1.50	2.00	2.52
	mm	7.9	9.9	15.0	19.3	25.0	32.0	38.1	51.0	64.0
B	INCHES	1.75	2.19	2.83	3.44	3.85	4.43	5.23	5.94	6.97
	mm	44.5	55.6	71.9	87.4	97.8	112.5	132.8	150.9	177.0
C	INCHES	0.88	1.14	1.42	1.72	1.93	2.23	2.62	2.97	3.49
	mm	22.2	29.0	36.1	43.7	49.0	56.6	66.5	75.4	88.6
D	INCHES	1.38	1.50	1.61	2.00	2.17	2.72	2.87	3.66	4.02
	mm	35.1	38.1	40.9	50.8	55.1	69.1	72.9	93.0	102.1
E	INCHES	3.31	3.31	3.31	4.65	4.65	5.28	5.28	7.87	7.87
	mm	84.1	84.1	84.1	118.1	118.1	134.1	134.1	199.9	199.9
F	TUBE SIZE Ø	.51	.63	.88	1.13	1.38	1.63	2.13	2.63	3.13
Cv		9	12	18	40	72	112	161	287	448

Note: DN (Diameter Nominal) = Metric equivalent size.

Rev. 5

The information presented on this sheet is correct at the time of publication. Milwaukee Valve reserves the right to change design, and/or material specifications without notice. For the most current information access www.milwaukeevalve.com

