

# BA-450/450S

# 3/8" - 2"

MSS SP-110

**BRONZE BALL VALVE  
TWO-PIECE, FULL-PORT  
600 PSIG WOG / 150 PSIG SWP (1)  
SOLDER ENDS**

### MATERIALS LIST

ITEM	PART	MATERIALS	ASTM SPEC.
1	Body	Cast Bronze	B584
2	Tailpiece	Brass	B16
		Cast Bronze (1 1/4" & up)	B584
3	Ball	Brass w/ Hard Chrome Plating	B16
		316 Stainless Steel (2)	A276
4	Seat	RPTFE, 15% Glass Filled Multi-Fil (3)	
5	Stem	Brass	B16
		316 Stainless Steel (2)	A276
6	Thrust Washer	RPTFE, 25% Glass Filled	
7	Packing	PTFE	
8	Packing Nut	Brass	B16
9	Handle	Steel w/ Zinc Plating	Commercial
10	Hand Grip	Vinyl	
11	Handle Nut	Steel w/ Zinc Plating	Commercial

- (1) Please consult factory for more information regarding steam applications.
- (2) Ball and stem are stainless for 450S.
- (3) For steam service, specify stainless trim and multi-fil seats, maximum stem pressure 150.

### PRESSURE - TEMPERATURE DATA

VALVES RATED FOR VACUUM SERVICE TO 29 INCHES Hg.

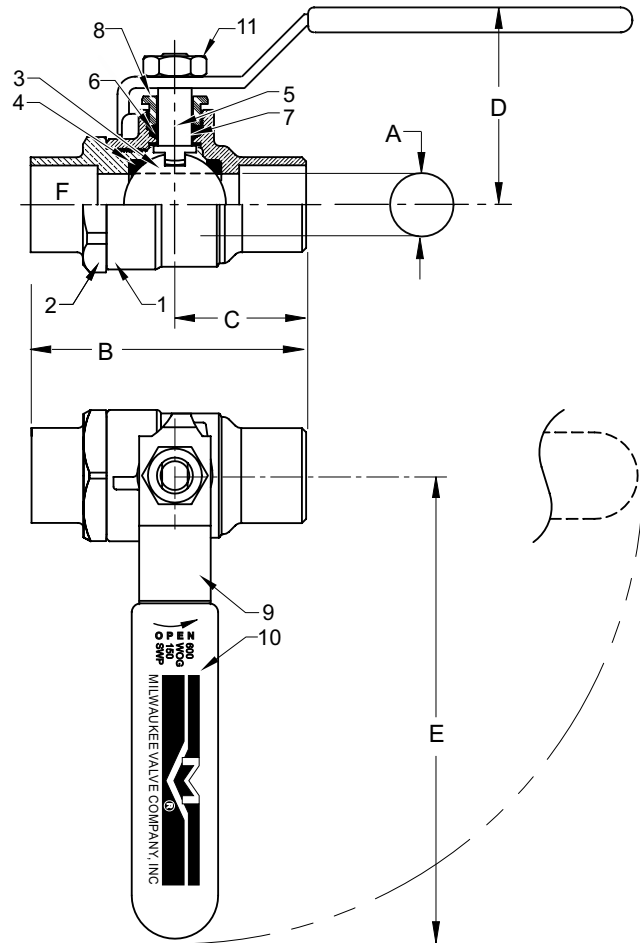
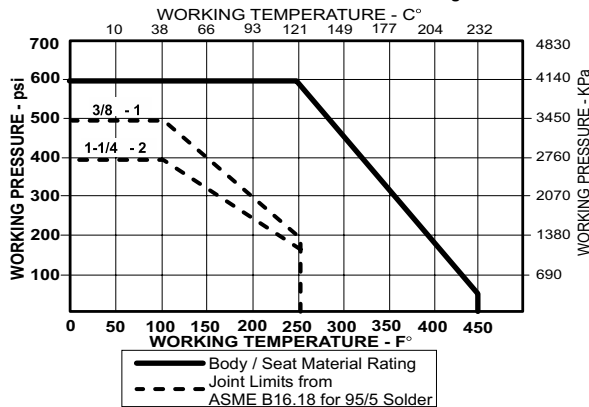

### DIMENSIONS

		3/8"	1/2"	3/4"	1"	1-1/4"	1-1/2"	2"
	UNITS	DN10	DN15	DN20	DM25	DM32	DN40	DN50
A(DIA)	INCHES	0.38	0.50	0.76	1.06	1.31	1.56	2.00
	mm	9.7	12.7	19.3	26.9	32.1	39.6	51.0
B	INCHES	2.05	2.39	3.17	3.75	5.00	6.00	6.75
	mm	52.0	58.6	80.5	95.3	127.0	152.4	171.5
C	INCHES	.91	1.07	1.50	1.79	2.49	3.00	3.37
	mm	23.1	27.2	38.1	45.5	63.3	76.2	85.6
D	INCHES	1.80	1.87	2.19	2.67	2.82	2.99	3.51
	mm	44.1	46.3	55.6	67.8	71.6	75.9	89.2
E	INCHES	3.80	3.80	4.56	6.31	6.31	6.31	7.19
	mm	96.5	96.5	115.8	160.3	160.3	160.3	182.6
F	TUBE							
	SIZE Ø	.51	.63	.88	1.13	1.38	1.63	2.13
Cv		7	15	35	60	110	185	360

Note: DN (Diameter Nominal) = Metric equivalent size.

Rev. 5

The information presented on this sheet is correct at the time of publication. Milwaukee Valve reserves the right to change design, and/or material specifications without notice. For the most current information access [www.milwaukeevalve.com](http://www.milwaukeevalve.com)

