



# Bronze Ball Valve For Potable Water Two-Piece • Full-Port 600 PSIG WOG Solder Ends

## UPBA450/450S 1/2" - 2"

Dimensions and workmanship conform to MSS SP-110  
Designed in accordance with the requirements of California AB 1953  
and Vermont S 152



WQA tested and Certified against WQA ORD0902 for California "lead free" compliance.

### MATERIALS LIST

ITEM	PART	MATERIALS	ASTM SPEC.
1	Body	Cast Bronze	B584 C89833
2	Tailpiece	Brass	B283 C46400
		Cast Bronze (1" & up)	B584 C89833
3	Ball	Brass w/ Hard Chrome Plating	B283 C46400
		316 Stainless Steel (1)	A276
4	Seat	RPTFE, 15% Glass Filled	
5	Stem	Brass	C89833
		316 Stainless Steel (1)	A276
6	Thrust Washer	RPTFE, 25% Glass Filled	
7	Packing	PTFE	
8	Packing Nut	Brass	B16
9	Handle	Steel w/ Zinc Plating	B633
10	Hand Grip	Vinyl	
11	Handle Nut	Steel w/ Zinc Plating	B633

(1) Ball and stem are stainless for UPBA450S.

### DIMENSIONS

	UNITS	1/2"	3/4"	1"	1-1/4"	1-1/2"	2"
		DN15	DN20	DM25	DM32	DN40	DN50
A(DIA)	INCHES	0.50	0.76	1.06	1.31	1.56	2.00
	mm	12.7	19.3	26.9	32.1	39.6	51.0
B	INCHES	2.39	3.17	3.75	5.00	6.00	6.75
	mm	58.6	80.5	95.3	127.0	152.4	171.5
C	INCHES	1.07	1.50	1.79	2.49	3.00	3.37
	mm	27.2	38.1	45.5	63.3	76.2	85.6
D	INCHES	1.87	2.19	2.67	2.82	2.99	3.51
	mm	46.3	55.6	67.8	71.6	75.9	89.2
E	INCHES	3.80	4.56	6.31	6.31	6.31	7.19
	mm	96.5	115.8	160.3	160.3	160.3	182.6
F	TUBE						
	SIZE Ø	.63	.88	1.13	1.38	1.63	2.13
Cv		15	35	60	110	185	360

Note: DN (Diameter Nominal) = Metric equivalent size.

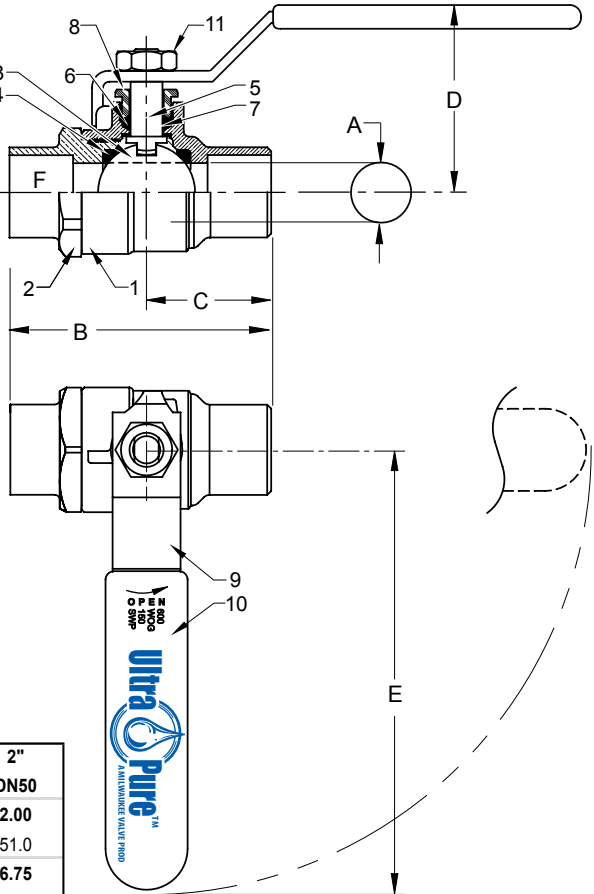

Rev 4

Milwaukee Valve Company  
16550 W. Stratton Drive  
New Berlin, WI 53151  
Phone: 262-432-2700  
Fax: 262-432-2701

**Note:** Lead free refers to the wetted surface of the pipe, fittings and fixtures in potable water systems that have a weighted average lead content 0.25%. Source: California Health and Safety Code (116875).

The information presented on this sheet is correct at the time of publication. Milwaukee Valve reserves the right to change design, and/or material specifications without notice. For the Installation, Operation and Maintenance Manual (IOM) see the engineering section on our website. For the most current information access [www.milwaukeevalve.com](http://www.milwaukeevalve.com)

