



Brass Ball Valve For Potable Water

Two-Piece • Full-Port

600 PSIG WOG

Threaded Ends

UPBA475B

1/4" - 2"

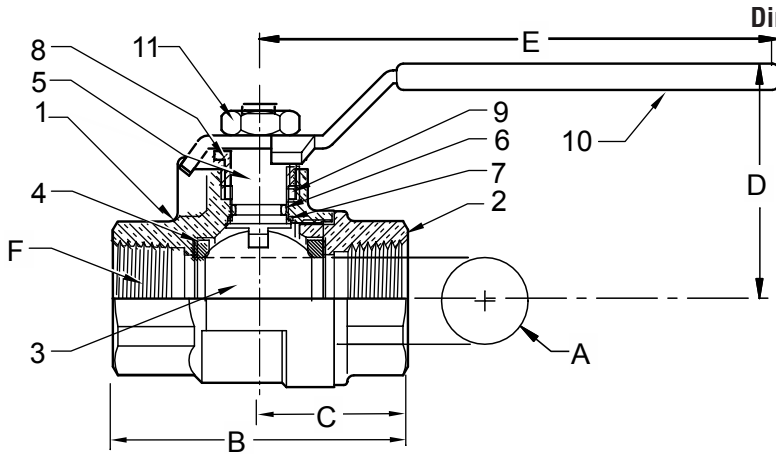

Dimensions and workmanship conform to MSS SP-110
ASME A112.4.14

*Also Available UPBA475B-LL
Designed in accordance with the
requirements of California AB 1953
and Vermont S 152



WQA tested and Certified
against WQA ORD0902
for California "lead free"
compliance.

MATERIALS LIST

ITEM	PART	MATERIALS	ASTM SPEC.
1	Body	Brass, Forged	B283 C46400
2	Tailpiece	Brass, Forged	B283 C46400
3	Ball	Brass w/ Chrome	B283 C46400 Chrome Plated
4	Ball Seal	PTFE	Commercial
5	Stem	Brass	B283 C46400
6	O-Ring	Buna-N	D2006
7	Thrust Washer	PTFE	Commercial
8	Gland Nut	Brass	B16
9	Packing	PTFE	Commercial
10	Handle	Zinc Plated Steel	Commercial
11	Handle Nut	Zinc Plated Steel	Commercial

DIMENSIONS

Valve Size	UNITS	1/4"	3/8"	1/2"	3/4"	1"	1-1/4"	1-1/2"	2"
A	INCHES	.39	.39	.51	.76	1.00	1.26	1.50	2.00
	mm	9.9	9.9	12.7	19.3	25.0	32.0	38.1	51.0
B	INCHES	1.87	1.87	2.25	2.62	3.06	3.5	3.75	4.38
	mm	47	47	57	67	78	89	95	111
C	INCHES	0.95	0.95	1.12	1.31	1.91	2.21	1.87	2.19
	mm	24	24	61	33	49	56	47	56
D	INCHES	1.42	1.42	1.46	1.93	2.10	2.33	2.52	2.96
	mm	36	36	37	49	53	59	64	75
E	INCHES	3.14	3.14	3.14	4.35	4.35	5.00	5.00	6.90
	mm	80	80	80	110	110	127	127	175
F	THREAD SIZE	1/4" NPT	3/8" NPT	1/2" NPT	3/4" NPT	1" NPT	1-1/4" NPT	1-1/2" NPT	2" NPT
Cv		12	12	18	40	72	112	161	287
TORQUE	in-lb	16	16	19	58	69	89	124	210
	N.m	1.8	1.8	2.1	6.5	7.8	10	14	24
WEIGHT	lbs	0.33	0.34	0.47	0.89	1.24	1.66	2.34	4.94
	Kg	.149	.155	.213	.403	.565	.755	1.064	2.245

Milwaukee Valve Company
16550 W. Stratton Drive
New Berlin, WI 53151
Phone: 262-432-2700
Fax: 262-432-2701

Rev 4

Note: Lead free refers to the wetted surface of the pipe, fittings and fixtures in potable water systems that have a weighted average lead content 0.25%. Source: California Health and Safety Code (116875).

The information presented on this sheet is correct at the time of publication. Milwaukee Valve reserves the right to change design, and/or material specifications without notice. For the Installation, Operation and Maintenance Manual (IOM) see the engineering section on our website. For the most current information access www.milwaukeevalve.com

