

# Our Experience Keeps Your Systems Flowing.

For more than 120 years, Milwaukee Valve has been producing valves for residential, commercial and industrial construction. This consistency and experience allow field repairs to be done quickly and efficiently with minimal downtime.

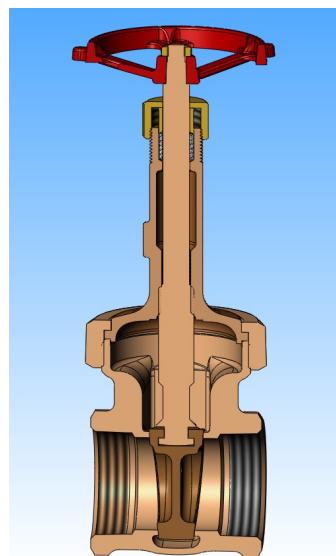

For example, take our domestically-produced bronze ball, gate, globe and check valves made in Prairie du Sac, WI. While manufacturing techniques and industry standards have evolved over the years, designed obsolescence is **not** in our nature. Engineered into every valve is the idea that components do wear over time. This thought process and vertically integrated manufacturing allows our customers to install with confidence and address field issues when they arise.

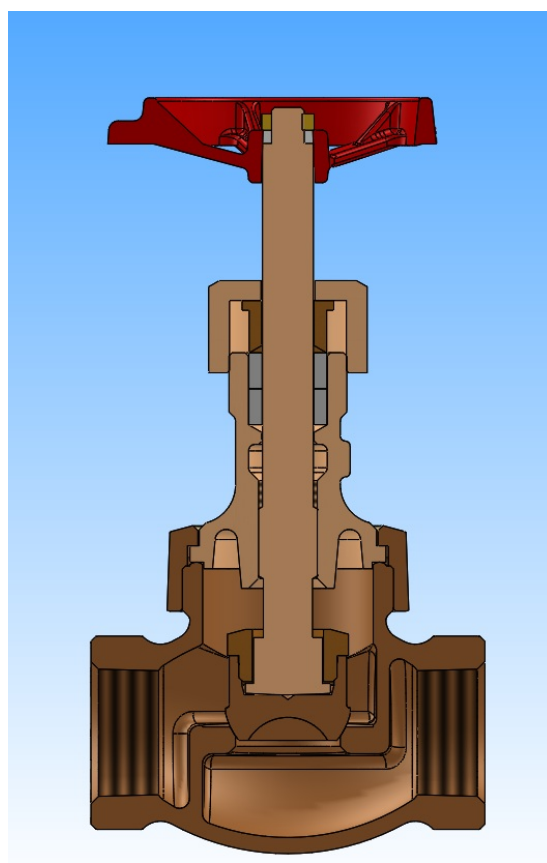

Need replacement packing for a gate valve? We've got you covered. Bent stem? Worn seats? Broken handwheel? Replacement check valve disc? PTFE seat for a ball or globe valve? All covered.

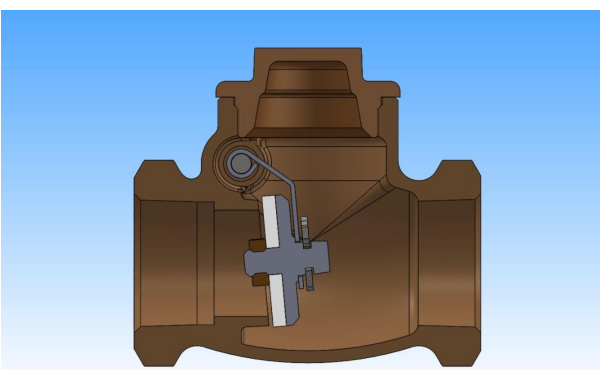

No skimping, no cutting corners. Just reliable valves backed by responsive innovation, knowledgeable product support, superior replacement parts, and more than 120 years of experience with bronze ball, gate, globe and check valves. Any questions or problems? Contact your [Milwaukee Valve customer service representative](#) today.

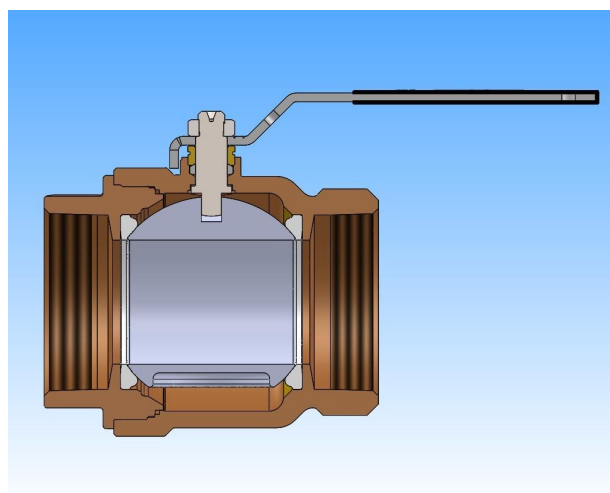

MILWAUKEE VALVE  
www.milwaukeevalve.com  
262.432.2700



HAMMOND VALVE  
www.hammondvalve.com  
262.432.2702



www.milwaukeevalve.com  
262.432.2700

16550 West Stratton Drive, New Berlin, WI 53151