



**MILWAUKEE VALVE**

Milwaukee Valve Company, LLC  
16550 W. Stratton Drive  
New Berlin, WI 53151  
Phone: 262.432.2700  
Fax: 262.432.2701  
www.milwaukeevalve.com

**TECHNICAL BULLETIN**

November 6, 2020  
MVTB-20-003

**Installing and Setting the Memory Stop (Option) on Gear Operated Rubber Lined and High Performance Butterfly Valves**

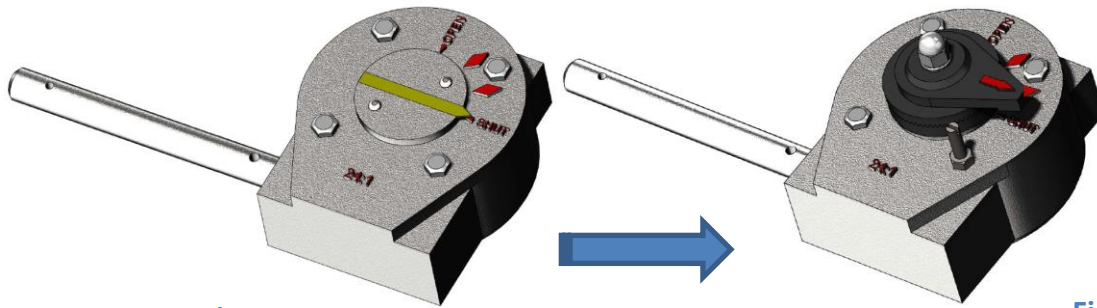

Figure 1

Figure 2

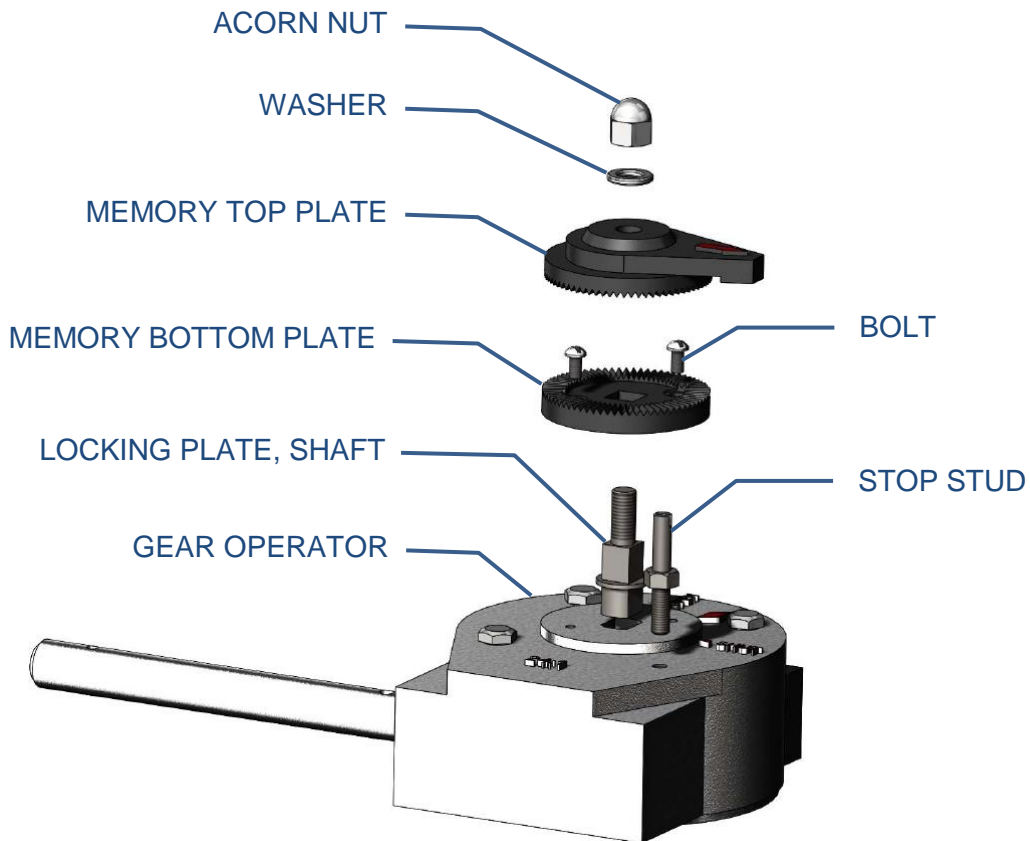

Figure 3

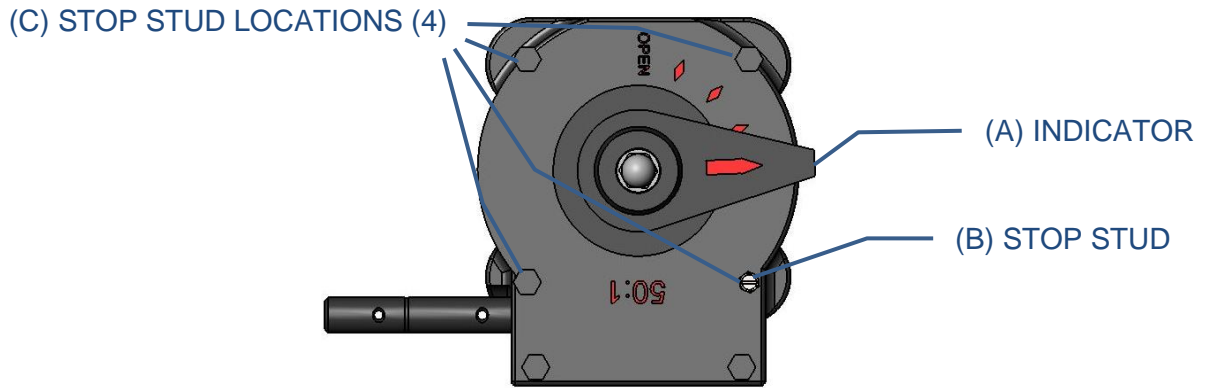

Figure 4

1. Ensure the yellow arrow of indicator plate is in shut position. Remove the 2 bolts and the indicator plate (Figure 1).
2. Install the locking plate shaft into the gear operator (Figure 3).
3. Install memory bottom plate over the locking plate shaft and tighten the 2 bolts (Figure 3).
4. Install the memory top plate. Position and set the indicator arm to stop at stop stud (Figure 4 (B)).
  - a) The stop stud can be placed in any one of the four holes (Figure 4 (C)) that hold the gear operator's top plate on, by loosening the lock nut with a wrench and using a slotted screwdriver to back the stud out.
5. Add the washer and tighten the acorn nut. The acorn nut can be removed allowing the indicator to be lifted and moved in another position if required (Figure 3).