

WIRING DIAGRAM

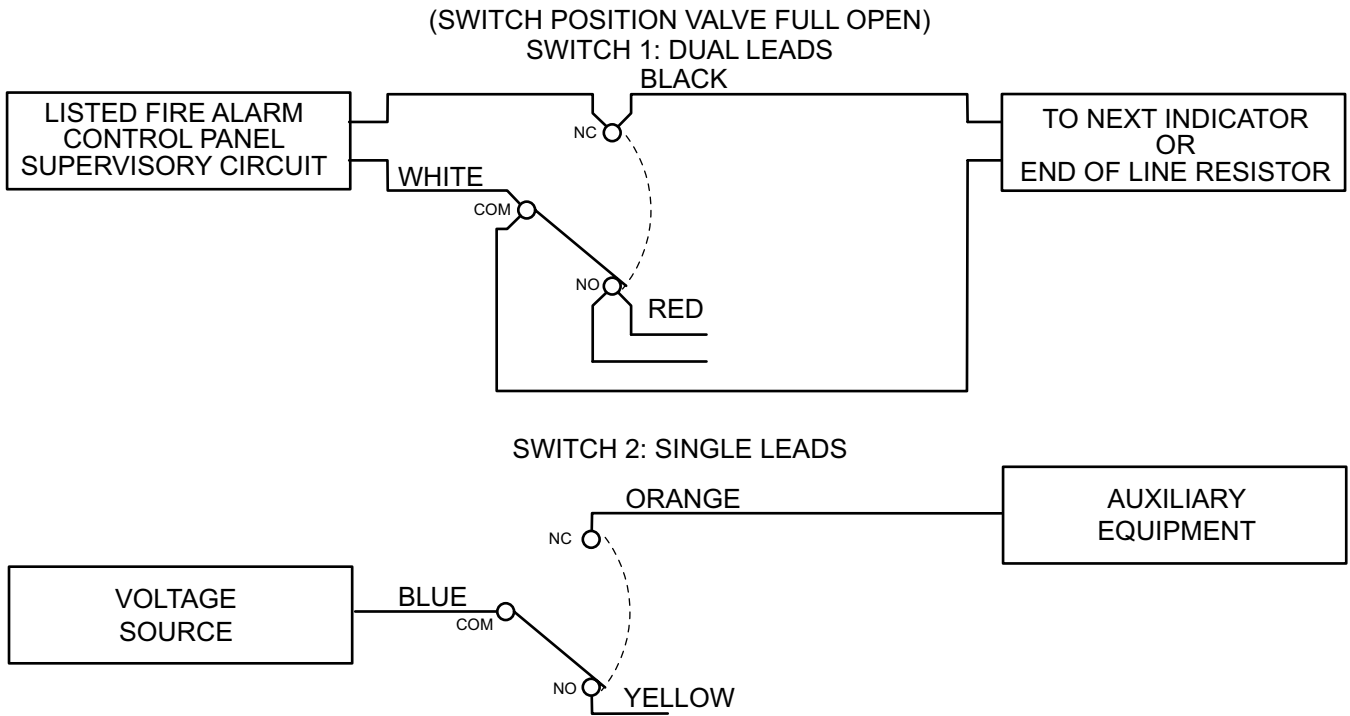

Green Lead provided is ground for switch housing

Switch Rating: 10 AMP/115 VAC
.5 AMP/28 VDC

Cap unused leads with wire nuts and tuck inside junction box (not provided)

NOTE: Valves incorporating supervisory tamper switches are for **indoor and outdoor use.**

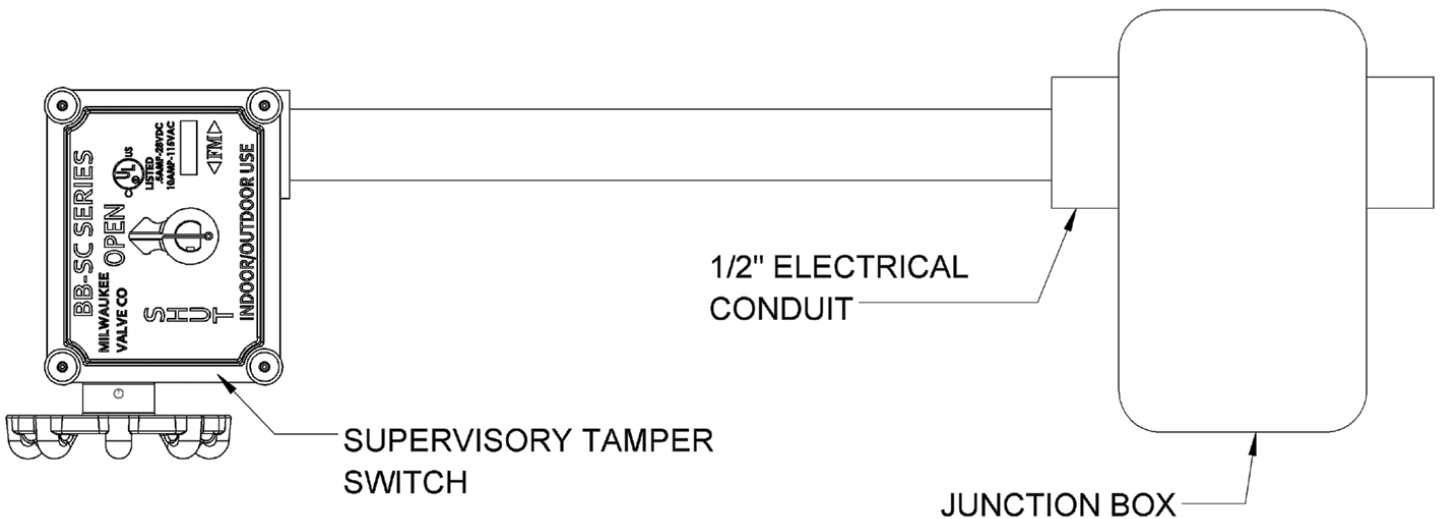

The information presented on this sheet is correct at time of publication. Milwaukee Valve reserves the right to change design and/or materials without notice. For our Installation, Operation and Maintenance Manual and the most current product information go to www.milwaukeevalve.com.
⚠ State of California Prop 65 **WARNING:** Cancer and Reproductive Harm. For more information visit www.p65warnings.ca.gov.

