

2887-M 1/4"-4" 2888-M 1/4"-4"

Iron Clip Gate Valve
 2887-M Bronze Trim • 2888-M All Iron
 1/4" - 2" 150 SWP - 225 WOG †
 2 1/2" - 4" 125 SWP -175 WOG †
 Inside Rising Stem • Solid Wedge Disc
 Threaded Ends

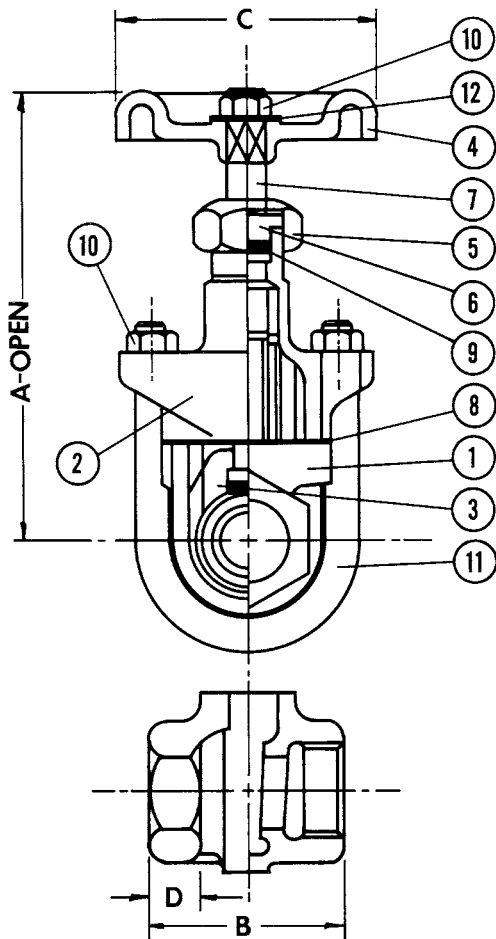

MATERIAL LIST			
No.	PART	MATERIAL	SPECIFICATION
1	Body	Ductile Iron-A 536	Ductile Iron-A 536
2	Bonnet	Ductile Iron-A 536	Ductile Iron-A 536
3	Disc	Cast Bronze-B 62	Ductile Iron-A 536
4	Handwheel	Cast Iron-A 126-B	Cast Iron-A 126-B
5	Packing Nut	Ductile Iron-A 536	Ductile Iron-A 536
6	Gland	Brass-B 16	410 SS
7	Stem	Brass-B 16	410 SS
8	Gasket	Commercial	Commercial
9	Packing	Commercial	Commercial
10	Nut	Steel-A 307-A	Steel-A 307-A
11	U-Bolt	Steel-A 307-A	Steel-A 307-A
12	Name Plate	Aluminum	Aluminum

DIMENSIONS - INCHES/MILLIMETERS						
Units	Size	A	B	C	D	C _v
Inches	1/4 - 1/2	5.00	2.09	2.13	0.47	5
mm		127	53	54	12	
Inches	3/4	6.22	2.52	2.44	0.51	32
mm		158	64	62	13	
Inches	1	7.50	2.64	2.95	0.63	54
mm		191	61	75	16	
Inches	1 1/4	9.00	2.91	2.95	0.70	97
mm		229	74	75	18	
Inches	1 1/2	9.14	3.15	3.75	0.75	135
mm		232	80	95	19	
Inches	2	11.58	3.90	3.98	0.75	230
mm		294	99	101	19	
Inches	2 1/2	12.88	4.60	4.75	0.90	337
mm		327	117	121	23	
Inches	3	14.70	4.92	6.00	0.90	536
mm		375	125	152	23	
Inches	4	19.30	5.94	9.00	0.98	960
mm		490	151	229	25	

Suffix M – Signifies “MILVACO” Series International Valves.
 † Non-Shock

INNOVATION IN EVERY VALVE

The information presented on this sheet is correct at time of publication. Milwaukee Valve reserves the right to change design and/or materials without notice. For our Installation, Operation and Maintenance Manual and the most current product information go to www.milwaukeevalve.com.  State of California Prop 65
WARNING: Cancer and Reproductive Harm. For more information visit www.p65warnings.ca.gov.



MILWAUKEE VALVE