

2974-FP 3"-8"

Iron Check Valve

175 WP WOG†

NEW YORK CITY BOARD OF STANDARDS and APPROVAL

Approvals: U.L. Listed, F.M.,
N.Y.C. B.S.A. No. 278-90-SM



Renewable Seat and Disc •
Flanged Ends Bolted Bonnet

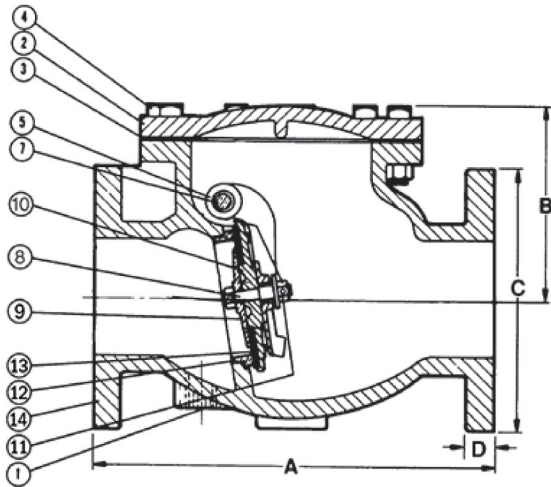

Note 1: On pump discharge, the preferred check valve is either an in-line spring loaded valve or a swing design with lever and weight. Install these valves as far as possible from the pump and elbows with a minimum distance of 5 times the pipe diameter.

MATERIAL LIST			
No.	Part	Material	Specification
1	Pipe Plug	Cast Iron or Steel	
2	Cover	Cast Iron	ASTM A126, Class B
3	Cover Gasket	Graphite	
4	Cover Bolt and Nut	Steel	ASTM A307
5	Hinge Plug	Cast Bronze	B 584 Alloy C84400
6	Hinge Pin	Brass	ASTM B16
7	Disc Hanger Nut	Cast Bronze	B 584 Alloy C84400
8	Disc Stud Bolt	Brass	ASTM B16 Alloy C36000
9	Disc Plate	Cast Bronze	B 584 Alloy C84400
10	Disc Hanger	Cast Bronze	B 584 Alloy C84400
11	Disc Nut	Brass	ASTM B16 Alloy C36000
12	Seat Ring	Cast Bronze	B 584 Alloy C84400
13	Disc	Rubber	
14	Body	Cast Iron	ASTM A126, Class B

DIMENSIONS - INCHES/MILLIMETERS						
Units	Size	A	B	C	D	Cv
Inches mm	3	10.25 260	6.63 168	7.50 191	0.75 19	356
Inches mm	4	13.00 330	8.00 203	9.00 229	0.94 24	665
Inches mm	6	16.25 413	10.31 262	11.00 279	1.00 25	1584
Inches mm	8	19.50 495	11.50 292	13.50 343	1.13 29	2937

† Non-Shock

INNOVATION IN EVERY VALVE

The information presented on this sheet is correct at time of publication. Milwaukee Valve reserves the right to change design and/or materials without notice. For our Installation, Operation and Maintenance Manual and the most current product information go to www.milwaukeevalve.com. ⚠ State of California Prop 65
WARNING: Cancer and Reproductive Harm. For more information visit www.p65warnings.ca.gov.

