

502 1/8"-3"

Bronze Globe Valve
125 SWP - 200 WOG †
Threaded Bonnet • Threaded Ends
Conforms to: MSS SP-80

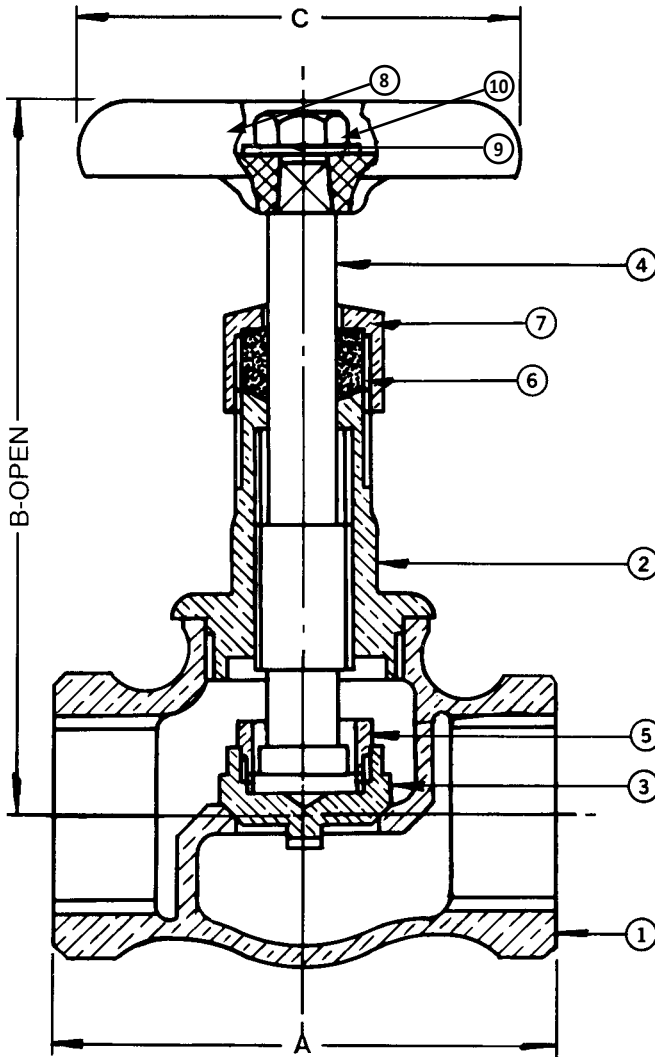

Note: Not intended for use in potable water.

MATERIAL LIST			
No.	PART	MATERIAL	SPECIFICATION
1	Body	Bronze	ASTM B62
2	Bonnet	Brass	ASTM B16, 1/8" - 1/2"
		Bronze	ASTM B62, 3/4" - 3"
3	Disc*	Brass	ASTM B453, 3/4" - 1-1/4"
		Bronze	ASTM B62, 1-1/2" - 3"
4	Stem	Brass	ASTM B505
5	Disc Ring*	Brass	ASTM B16, 3/4" - 2", 3"
		Bronze	ASTM B62, 2-1/2"
6	Packing	Graphite	Commercial
7	Packing Nut	Brass	ASTM B16, 1/8" - 3/4", 1-1/4" - 2"
		Brass	ASTM B283, 1"
		Bronze	ASTM B584, 2-1/2"
		Bronze	ASTM B62, 3"
8	Handwheel	Mall. Iron	Commercial
9	Name Plate	Aluminum	Commercial
10	Handwheel Nut	Brass	Commercial
11	Gland (not shown)	Brass	ASTM B16, 2-1/2" and 3" only

* 1/8" to 1/2" sizes have the disc integral with the stem

DIMENSIONS - INCHES/MILLIMETERS					
Units	Size	A	B	C	C _v
Inches mm	1/8	1.63 41	3.06 78	2.00 51	0.61
Inches mm	1/4	1.63 41	3.06 78	2.00 51	1.16
Inches mm	3/8	1.81 46	3.19 81	2.00 51	2.21
Inches mm	1/2	2.31 59	3.63 92	2.00 51	3.64
Inches mm	3/4	2.56 65	3.94 100	2.50 64	6.65
Inches mm	1	2.94 75	4.38 111	2.75 70	11.10
Inches mm	1 1/4	3.38 86	5.19 132	3.44 87	20.00
Inches mm	1 1/2	3.69 94	5.75 146	3.75 95	28.00
Inches mm	2	4.44 113	6.75 172	4.25 108	48.00
Inches mm	2 1/2	5.75 146	8.63 219	4.75 121	70.00
Inches mm	3	7.50 191	9.25 235	5.50 140	111.00

† Non-Shock

INNOVATION IN EVERY VALVE

The information presented on this sheet is correct at time of publication. Milwaukee Valve reserves the right to change design and/or materials without notice. For our Installation, Operation and Maintenance Manual and the most current product information go to www.milwaukeevalve.com.  State of California Prop 65
WARNING: Cancer and Reproductive Harm. For more information visit www.p65warnings.ca.gov.

MILWAUKEE VALVE