

# BA-480S\* 1/2"-2"



Tested and Certified by IAMPO R&T to:  
NSF/ANSI/CAN Z1157.

Brass Ball Valve  
Two Piece  
Full Port  
250 psig @ 250°F†  
Press x Press Ends  
Blow-Out Proof Stem

† Non-Shock

\*Not intended for use in potable water.

## MATERIALS LIST

ITEM	PART	MATERIALS	ASTM SPEC.
1	Body	Brass, Forged	B283
2	Tailpiece	Brass, Forged	B283
3	Ball	316 S.S.	A276
4	Ball Seat	PTFE	Commercial
5	Stem	316 S.S.	A276
6	Stem O-Ring	Buna-N	Commercial
7	Thrust Washer	PTFE	Commercial
8	Gland Nut	Brass	B124
9	Packing	PTFE	Commercial
10	Handle	Steel x/Zinc Plating	Commercial
11	Handle Nut	Steel x/Zinc Plating	Commercial

\* UltraPress Valves are designed and qualified for use in copper tubing systems only, Types K, L, & M per ASTM B88.

\*\* For Installation Instructions please see engineering section on website.

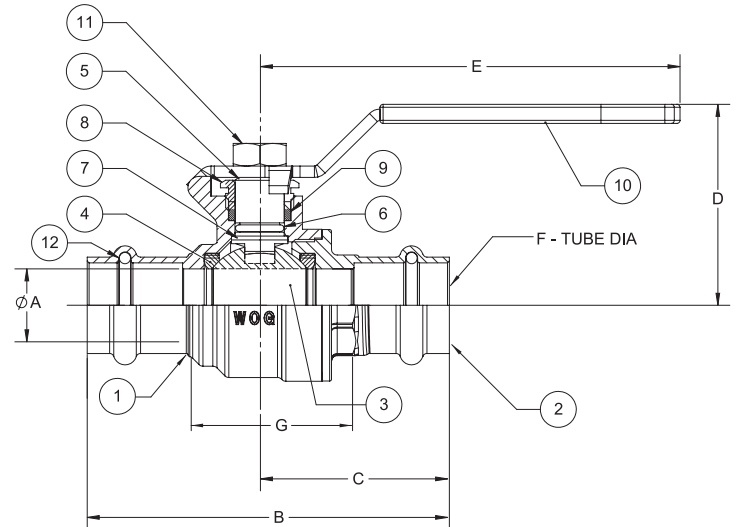

## DIMENSIONS

	UNITS	1/2" DN15	3/4" DN20	1" DN25	1-1/4" DN32	1-1/2" DN40	2" DN50
A	INCHES	0.51	0.76	0.98	1.26	1.5	2.01
	mm	13	19	25	32	38	51
B	INCHES	3.16	3.71	4.28	5.2	6.31	7.44
	mm	80	94	109	132	160	189
C	INCHES	1.63	1.92	2.18	2.75	3.4	3.96
	mm	41	49	55	70	86	101
D	INCHES	1.62	2.01	2.21	2.46	2.62	3.13
	mm	41	51	56	63	67	80
E	INCHES	3.15	4.33	4.33	5.12	5.12	6.89
	mm	80	110	110	130	130	175
G	INCHES	1.52	1.73	2.31	3.16	3.49	4.28
	mm	39	44	59	80	89	109
Cv		18	40	72	112	161	287

The information presented on this sheet is correct at time of publication. Milwaukee Valve reserves the right to change design and/or materials without notice. For our Installation, Operation and Maintenance Manual and the most current product information go to [www.milwaukeevalve.com](http://www.milwaukeevalve.com).

⚠ State of California Prop 65 **WARNING:** Cancer and Reproductive Harm. For more information visit [www.p65warnings.ca.gov](http://www.p65warnings.ca.gov).

