

# BA-490S\* 1/2"-2"



Brass Ball Valve  
Two Piece  
Full Port  
200 psig @ 250°F†  
Press x Threaded Ends  
Blow-Out Proof Stem

\*Not intended for use in potable water.

## MATERIALS LIST

ITEM	PART	MATERIALS	ASTM SPEC.
1	Body	Brass, Forged	B283
2	Tailpiece	Brass, Forged	B283
3	Ball	316 S.S.	A276
4	Ball Seat	PTFE	Commercial
5	Stem	316 S.S.	A276
6	Stem O-Ring	Buna-N	
7	Thrust Washer	PTFE	Commercial
8	Gland Nut	Brass	B124
9	Packing	PTFE	Commercial
10	Handle	Steel w/Zinc Plating	Commercial
11	Handle Bolt	Steel w/Zinc Plating	Commercial
12	Tube O-Ring	EPDM	D2000 NSF61

\*UltraPress Valves are designed and qualified for use in copper tubing systems only, Types K, L, & M per ASTM B88.

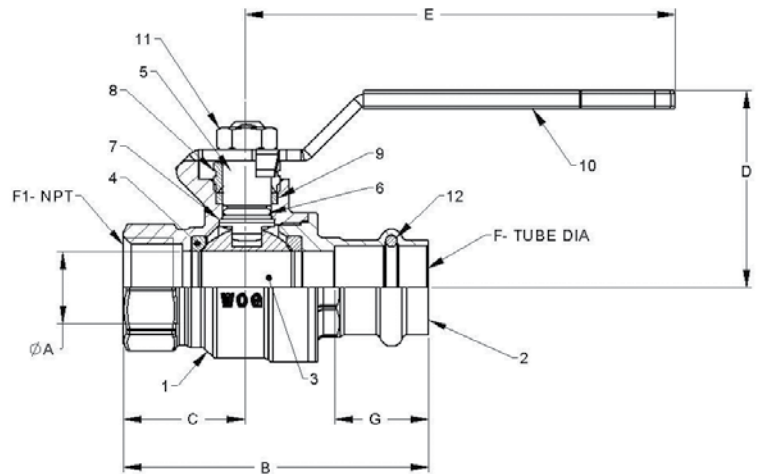

## DIMENSIONS

	UNITS	1/2" DN15	3/4" DN20	1" DN25	1-1/4" DN32	1-1/2" DN40	2" DN50
A-PORT DIA	INCHES	0.51	0.76	0.98	1.26	1.50	2.00
	mm	13	19	25	32	38	51
B	INCHES	2.77	3.23	3.71	4.12	4.86	6.14
	mm	70	82	94	105	123	156
C	INCHES	1.14	1.31	1.53	1.71	1.88	2.19
	mm	29	33	39	43	48	56
D	INCHES	1.46	1.93	2.10	2.33	2.52	2.96
	mm	37	49	53	59	64	75
E	INCHES	3.14	4.35	4.35	5.00	5.00	6.90
	mm	80	110	110	127	127	175
F-TUBE DIA	INCHES	0.63	0.88	1.13	1.38	1.63	2.13
	mm	15	20	25	32	40	50
F1 NPT	Inches	1/2"-14	3/4"-14	1"-11.5	1-1/4"-11.5	1-1/2"-11.5	2"-11.5
G	INCHES	0.83	1.00	1.00	1.02	1.42	1.57
	mm	21	25	25	26	36	40
Cv		18	40	72	112	161	287

The information presented on this sheet is correct at time of publication. Hammond Valve reserves the right to change design and/or materials without notice. For our Installation, Operation and Maintenance Manual and the most current product information go to [www.hammondvalve.com](http://www.hammondvalve.com). Hammond Valve is a registered trademark of Milwaukee Valve.

⚠ State of California Prop 65 **WARNING:** Cancer and Reproductive Harm. For more information visit [www.p65warnings.ca.gov](http://www.p65warnings.ca.gov).