

ML Series 14" - 24"

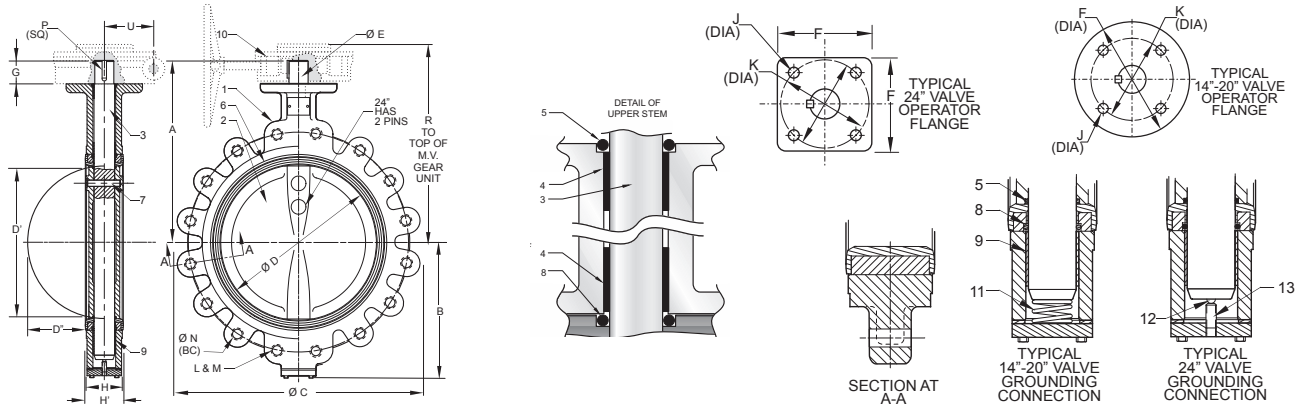

ABS Type Approved; Cat. A
CFR-46

**Iron Butterfly Valve
Lug Style
150 psi Non-Shock WOG
Dead End Service to 150 psi Max*
Specifications: MSS SP-67 Type 1**



MATERIALS

ITEM	PART	MATERIALS
1	BODY	CAST IRON ASTM A126 CL. B
		DUCTILE IRON ASTM A536
		DUCTILE IRON-EPOXY COATED
2	DISC	NP DUCTILE IRON ASTM A536
		ALUMINUM BRONZE ASTM B148
		STAINLESS STEEL TYPE 316
3	STEM	STAINLESS STEEL TYPE 416
		STAINLESS STEEL TYPE 316 (3)
4	TOP BEARING	REINFORCED NYLON
5	STEM O-RING	EPDM, BUNA, VITON (1)
6	LINER	BUNA
		EPDM
		VITON
		HYPALON
7	STEM PIN	ANSI 4140 OR AISI 6150
8	LINER O-RING	EPDM, BUNA, VITON (1)
9	LOWER BEARING	REINFORCED NYLON
10	OPERATOR	GEAR OPERATOR
		GEAR OPERATOR WITH MEMORY STOP
		GEAR OPERATOR WITH LOCK
		ACTUATOR-AIR/AIR (2)
		ACTUATOR-AIR/SRING (2)
ACTUATOR-ELECTRIC (2)		
11 14"-20"	GROUNDING SPRING	STAINLESS STEEL TYPE 302
12 24" Only	GROUNDING BALL	AISI-1022
13 24" Only	TENSION SCREW	AISI-1020

(1) - Viton O-rings are used with Hypalon liner

(2) - Consult Automation Department

(3) - 316 Stem used with CF8M disc

* Uni-directional

Note: The wetted surface of this product (In any material combination.) contacted by consumable water contains less than one quarter of one percent (.25%) of lead by weight.

The information presented on this sheet is correct at time of publication. Milwaukee Valve reserves the right to change design and/or materials without notice. For our Installation, Operation and Maintenance Manual and the most current product information go to www.milwaukeevalve.com.

⚠ State of California Prop 65 **WARNING:** Cancer and Reproductive Harm. For more information visit www.p65warnings.ca.gov.

DIMENSIONS

	INCHES DN	VALVE SIZE				
		14	16	18	20	24
A	INCHES	15.50	16.75	18.50	19.75	22.43
	mm	398	425	469	501	569
B	INCHES	11.56	12.69	13.63	15.13	18.06
	mm	258	322	346	384	458
C	INCHES	21.00	23.50	25.00	27.50	32.10
	mm	533	596	635	698	815
D	INCHES	13.25	15.25	17.24	19.24	23.25
	mm	336	387	438	489	591
D ¹ (Chord Dia.)	INCHES	12.94	14.77	16.70	18.64	22.49
	mm	329	375	424	474	571
D ¹¹ (Intrusion)	INCHES	5.06	5.59	6.34	7.09	8.55
	mm	128	142	161	180	217
E	INCHES	1.63	1.63	2.13	2.13	2.13
	mm	41	41	54	54	54
F	INCHES	6.50	6.50	9.50	9.50	7.50
	mm	165	165	241	241	190
G	INCHES	2.00	2.00	3.00	3.00	3.06
	mm	50	50	76	76	77
H (Body)	INCHES	3.06	4.00	4.50	5.00	6.06
	mm	77	101	114	127	153
H ¹ (Liner)	INCHES	3.19	4.13	4.63	5.13	6.19
	mm	81	104	117	130	157
J	INCHES	0.69	0.69	0.81	0.81	0.81
	mm	17	17	20	20	20
K	INCHES	5.25	5.25	7.50	7.50	7.50
	mm	133	133	190	190	190
L	No. of Holes	12	16	16	20	20
M	Thread Size	1-8	1-8	1 1/8-7	1 1/8-7	1 1/4-7
N	INCHES	18.75	21.25	22.75	25.00	29.50
	mm	476	530	577	635	749
P (Key Size)	INCHES	0.38	0.38	0.50	0.50	0.50
	mm	9	9	12	12	12
R	INCHES	17.25	18.75	19.63	20.88	25.00
	mm	438	475	458	530	635
U	INCHES	3.13	3.13	4.50	4.50	4.63
	mm	79	79	114	114	117



M**L****2****3****4****V****A**

VALVE SERIES	BODY STYLE	OPERATOR	BODY MATERIAL	DISC MATERIAL	LINER MATERIAL	SPECIAL OPTIONS
H - H SERIES (250 PSI)	L - LUG BODY	1 - VALVE ONLY	2 - CAST IRON*	2 - NICKEL PLATED DUCTILE IRON	B - BUNA-N	S - 316 STEM W/AB OR NP DISC
M - M SERIES	W - WAFER BODY	2 - LEVER HANDLE	3 - DUCTILE IRON	3 - ALUMINUM/BRONZE	E - EPDM	A - EPOXY COATED BODY
O - O SERIES		3 - GEAR OPERATOR		4 - CF8M(316) STAINLESS STEEL	H - HYPALON	DA - DRY ASSEMBLED
U - U SERIES (50 PSI)		5 - GEAR W/MEMORY STOP	*MILWAUKEE VALVE	7 - NYLON COATED DUCTILE IRON	NB - FDA BLACK NEOPRENE	
		9 - GEAR WITH LOCK	RESERVES THE RIGHT TO UPGRADE THE BODY WITHOUT NOTICE FOR NO ADDITIONAL COST.	8 - EPOXY COATED DUCTILE IRON	NW - FDA WHITE NEOPRENE	
					T - TEFLON OVER BUNA (AVAILABLE W/SS DISC ONLY)	
					V - VITON	
		*PNEUMATIC AND ELECTRIC ACTUATION OPTIONS AVAILABLE				

Rev 11/4/2021