

ML Series 30" - 48"

**Iron Butterfly Valve
Lug Style
150 psi Non-Shock WOG
ASME B16.47 Series A Flanges
Specifications: MSS SP-67 Type 1**

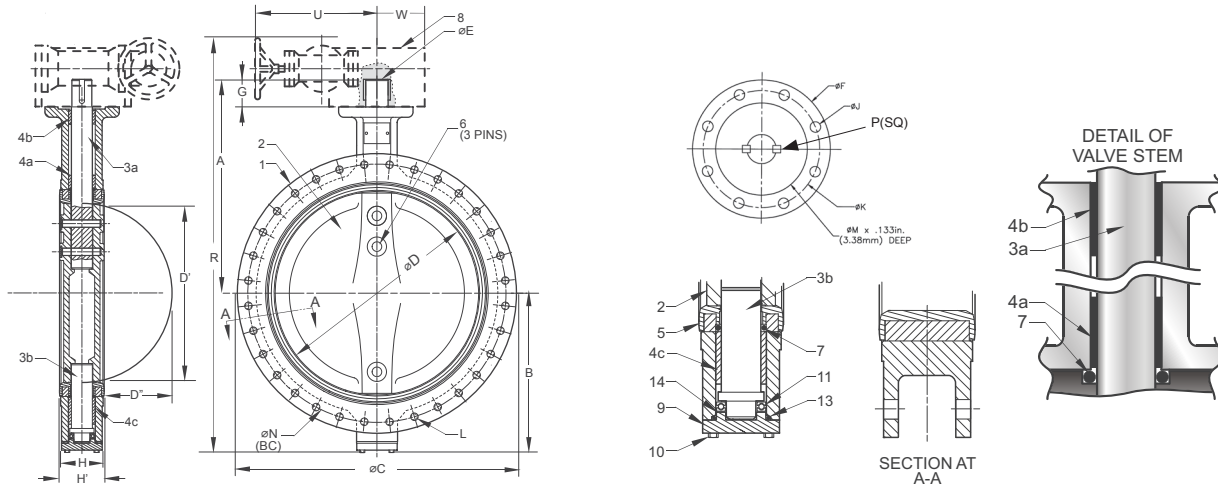

MATERIALS LIST

ITEM	PART	MATERIALS
1	BODY	CAST IRON ASTM A126 CL. B
		DUCTILE IRON ASTM A536
2	DISC	ALUMINUM BRONZE ASTM B148 C95400
		NP DUCTILE IRON ASTM A536
		STAINLESS STEEL ASTM A351 CF8M
3a	UPPER STEM	STAINLESS STEEL TYPE 410
3b	LOWER STEM	STAINLESS STEEL TYPE 410
4a	UPPER STEM BEARING, SHORT	CAST BRASS
4b	UPPER STEM BEARING, LONG	CAST BRASS
4c	LOWER STEM BEARING	CAST BRASS
5	LINER	BUNA
		EPDM
		VITON
6	STEM PIN	STAINLESS STEEL TYPE 302
7	LINER O-RING	BUNA
8	OPERATOR	GEAR OPERATOR
		ACTUATOR-AIR/AIR (1)
		ACTUATOR-AIR/SRING (1)
9	BOTTOM CAP	ASTM A126 CL.B
10	BOTTOM CAP FASTENING BOLTS	CARBON STEEL 8.8
11	THRUST BEARING	AISI-1020
12	KEY	SS410
13	BOTTOM CAP O-RING	BUNA
14	THRUST BEARING GASKET	ASTM A570 Gr. 33

(1) - Consult Automation Department.

DIMENSIONS

	INCHES DN	VALVE SIZE			
		30	36	42	48
A	INCHES	29.72	33.46	39.69	42.95
	mm	755	850	1008	1091
B	INCHES	22.01	25.83	30.60	34.02
	mm	559	656	777	864
øC	INCHES	38.74	45.98	53.00	59.49
	mm	984	1168	1346	1511
øD	INCHES	29.29	34.04	40.55	45.67
	mm	744	864	1030	1160
D ¹ (Chord Dia.)	INCHES	28.56	33.10	39.33	44.35
	mm	725	840	999	1126
D ¹¹ (Intrusion)	INCHES	11.30	13.00	15.20	17.10
	mm	287	330	386	434
øE	INCHES	2.49	2.95	3.35	4.13
	mm	63	75	85	105
øF (Mtg. Flange)	INCHES	11.81	11.81	11.81	13.78
	mm	300	300	300	350
G	INCHES	3.74	5.12	5.91	5.91
	mm	95	130	150	150
H (Body Width)	INCHES	6.50	8.00	9.88	10.88
	mm	165	203	251	276
H ¹ (Liner Width)	INCHES	6.89	8.31	10.27	11.26
	mm	175	211	261	286
øJ	INCHES	0.71			
	mm	18			
øK B.C.	INCHES	10.00			
	mm	254			
L	No. of Holes (per Flange) Thread	See Flange Bolting Table in Butterfly Catalog			
	Bolt Size				
øM	INCHES	7.87			9.06
	mm	200			230
øN	INCHES	36.00	42.75	49.50	56.00
	mm	914	1086	1257	1422
P (Square Key Size)	INCHES	0.71	0.79	0.87	1.10
	mm	18	20	22	28
R	INCHES	62.80	68.98	79.17	89.43
	mm	1595	1752	2011	2271.5
U	INCHES	13.23	14.06	14.06	17.72
	mm	336	357	357	450
W	INCHES	5.75	6.65	6.65	7.13
	mm	146	169	169	181

Note: The wetted surface of this product (In any material combination.) contacted by consumable water contains less than one quarter of one percent (.25%) of lead by weight.

The information presented on this sheet is correct at time of publication. Milwaukee Valve reserves the right to change design and/or materials without notice. For our Installation, Operation and Maintenance Manual and the most current product information go to www.milwaukeevalve.com.

⚠ State of California Prop 65 **WARNING:** Cancer and Reproductive Harm. For more information visit www.p65warnings.ca.gov.



M**L****2****3****4****V****A**

VALVE SERIES	BODY STYLE	OPERATOR	BODY MATERIAL	DISC MATERIAL	LINER MATERIAL	SPECIAL OPTIONS
H - H SERIES (250 PSI)	L - LUG BODY	1 - VALVE ONLY	2 - CAST IRON*	2 - NICKEL PLATED DUCTILE IRON	B - BUNA-N	S - 316 STEM W/AB OR NP DISC
M - M SERIES	W - WAFER BODY	2 - LEVER HANDLE	3 - DUCTILE IRON	3 - ALUMINUM/BRONZE	E - EPDM	A - EPOXY COATED BODY
O - O SERIES		3 - GEAR OPERATOR		4 - CF8M(316) STAINLESS STEEL	H - HYPALON	DA - DRY ASSEMBLED
U - U SERIES (50 PSI)		5 - GEAR W/MEMORY STOP	*MILWAUKEE VALVE	7 - NYLON COATED DUCTILE IRON	NB - FDA BLACK NEOPRENE	
		9 - GEAR WITH LOCK	RESERVES THE RIGHT TO	8 - EPOXY COATED DUCTILE IRON	NW - FDA WHITE NEOPRENE	
			UPGRADE THE BODY		T - TEFLON OVER BUNA	
			WITHOUT NOTICE FOR NO		(AVAILABLE W/SS DISC ONLY)	
			ADDITIONAL COST.		V - VITON	
		*PNEUMATIC AND ELECTRIC				
		ACTUATION OPTIONS AVAILABLE				

Rev 11/4/2021