

SWING CHECK P-2519A
ALUMMINUM
 Dry Bulk Transports • Tank Truck
 Aluminum Disc With Viton® Seat
 150 WOG †

A rugged multi-purpose swing check for general tank and loading rack installations. All the advantages of full flow afforded by swing check design, near silent operation, leak resistance and quick cap removal; stainless steel pin and plugs.

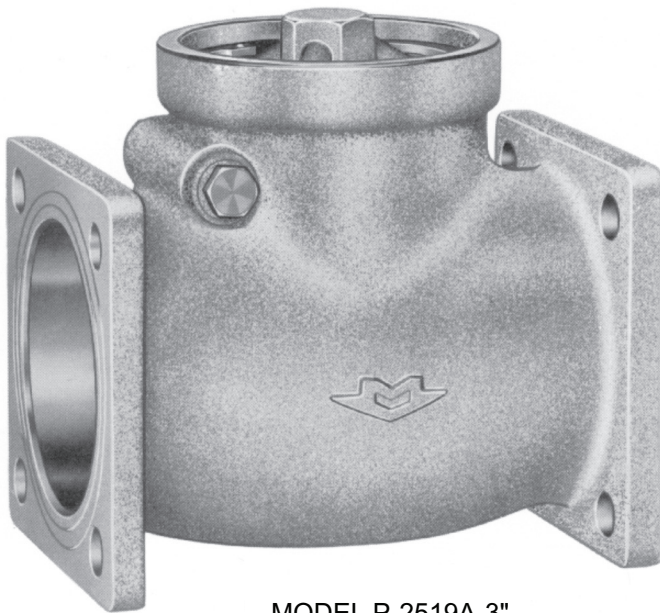

MODEL P-2519A-3"

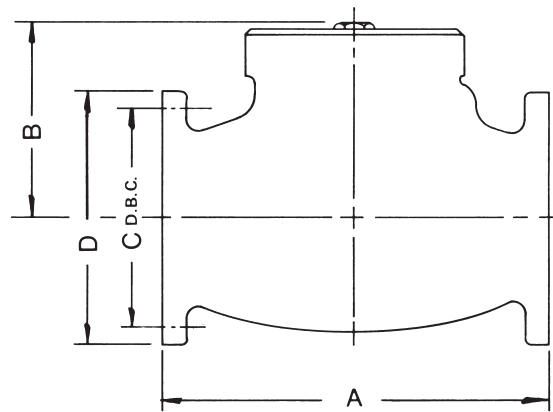

DIMENSIONS-INCHES

| SIZE | A | B | C | D | E | F |
|------|-------|--------|---|-------|---|------|
| 3 | 6 7/8 | 4 1/16 | 5 | 4 3/4 | 4 | 9/16 |

DIMENSION DESCRIPTION

| | |
|----------|----------------------|
| C | Diameter Bolt Circle |
| D | For 3" Square Flange |
| E | Number of Bolt Holes |
| F | Size of Bolt Holes |

† Non-Shock

NOTE: P-2519-4" Also Available - Consult Factory.

The information presented on this sheet is correct at time of publication. Milwaukee Valve reserves the right to change design and/or materials without notice. For our Installation, Operation and Maintenance Manual and the most current product information go to www.milwaukeevalve.com.
 ⚠ State of California Prop 65 **WARNING:** Cancer and Reproductive Harm. For more information visit www.p65warnings.ca.gov.

