

P900 1"-3"

Bronze Gate Valve
150 SWP - 300 WOG †
Quick Opening • Self Closing
Lever Operated • Double Disc • Threaded Ends

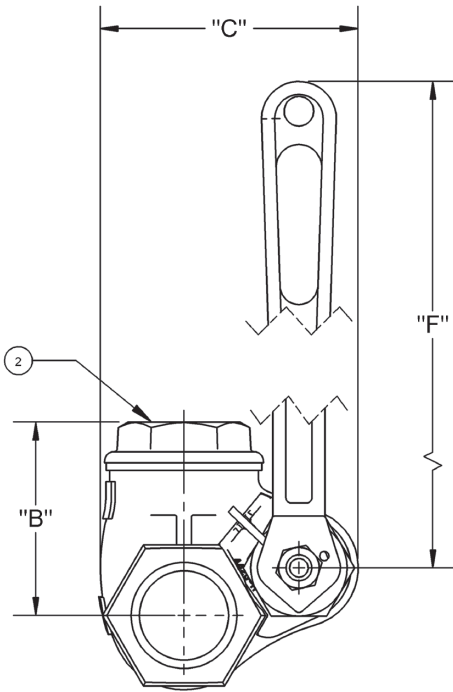

MATERIAL LIST			
No.	PART	MATERIAL	SPECIFICATION
1	Body	Bronze	ASTM B62
2	Cap	Bronze	ASTM B62
3	Lever	Bronze	ASTM B62
4	Male Disc	Brass	ASTM B16
5	Female Disc	Brass	ASTM B16
6	Bonnet	Bronze	ASTM B62
7	Stem	Brass	ASTM B16
8	Gland	Brass	ASTM B16
9	Packing Nut	Bronze	ASTM B62
10	Packing	Graphite	
11	Locknut Bracket	Bronze	ASTM B16
12	Gland Spring	Steel	
13	Spring, Torsion	Steel	
14	Spring Bracket	Bronze	ASTM B62
15	Handle Lever, Drilled	Mall. Iron	
16	Handle Nut	Steel	

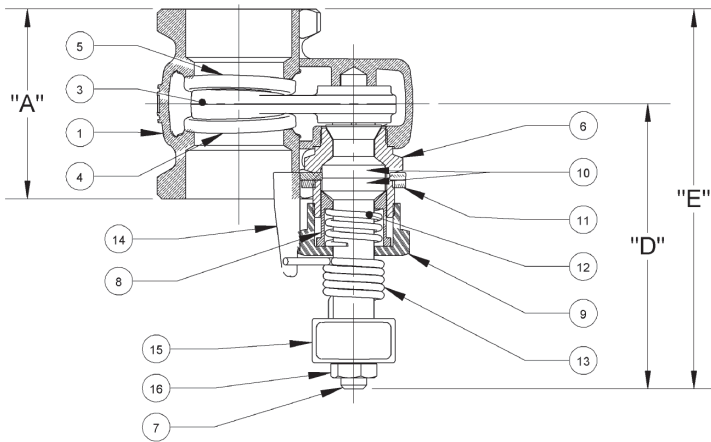

DIMENSIONS - INCHES/MILLIMETERS							
Units	Size	A	B	C	D	E	F
Inches	1	2.50	2.38	3.37	4.31	5.56	7.00
mm		64	60	86	109	141	178
Inches	1 1/4	2.88	2.81	3.84	4.44	5.88	8.19
mm		73	71	98	113	149	208
Inches	1 1/2	3.18	3.25	4.34	4.79	6.38	10.50
mm		81	83	110	122	162	267
Inches	2	3.75	4.12	5.31	5.41	7.28	10.50
mm		95	105	135	137	185	267
Inches	2 1/2	4.25	4.50	5.94	5.47	7.59	11.51
mm		108	114	151	139	193	292
Inches	3	4.75	5.63	7.02	5.59	7.97	11.50
mm		121	143	178	142	202	292

† Non-Shock

Note: Not intended for use in potable water.

INNOVATION IN EVERY VALVE



MILWAUKEE VALVE

The information presented on this sheet is correct at time of publication. Milwaukee Valve reserves the right to change design and/or materials without notice. For our Installation, Operation and Maintenance Manual and the most current product information go to www.milwaukeevalve.com. State of California Prop 65 **WARNING:** Cancer and Reproductive Harm. For more information visit www.p65warnings.ca.gov.