



UPBA100/100S 1/4"-3"



Bronze Ball Valve For Potable Water
Two Piece
Standard Port (1" - 3") Full Port (1/4" - 3/4")
600 psig WOG
Threaded Ends
Blow-Out Proof Stem
Dimensions and Workmanship Conform to MSS SP-110

MATERIAL LIST

ITEM	PART	MATERIAL	ASTM SPEC
1	Body	Cast Bronze	B584 C89833
2	Tailpiece	Cast Bronze	B584 C89833
3	Ball	Brass w/Hard Chrome Plating	B283 C27450
		316 Stainless Steel (1)	A276 S31600
4	Seat	RPTFE, 15% Glass filled	Commercial
5	Stem	Brass	B21 C46400
		316 Stainless Steel (1)(2)	A276 S31600
6	Thrust Washer	RPTFE, 25% Glass Filled	Commercial
7	Packing	PTFE	Commercial
8	Packing Nut	Brass	B16 C36000
9	Handle	Steel w/Zinc Plating	B633
10	Handle Grip	Vinyl	Commercial
11	Handle Nut	Steel w/Zinc Plating	B633
12*	Body Seal	PTFE	Commercial

(1) Ball and stem are stainless for UPBA100S

(2) Ball and stem are stainless for 2 1/2" & 3" UPBA100

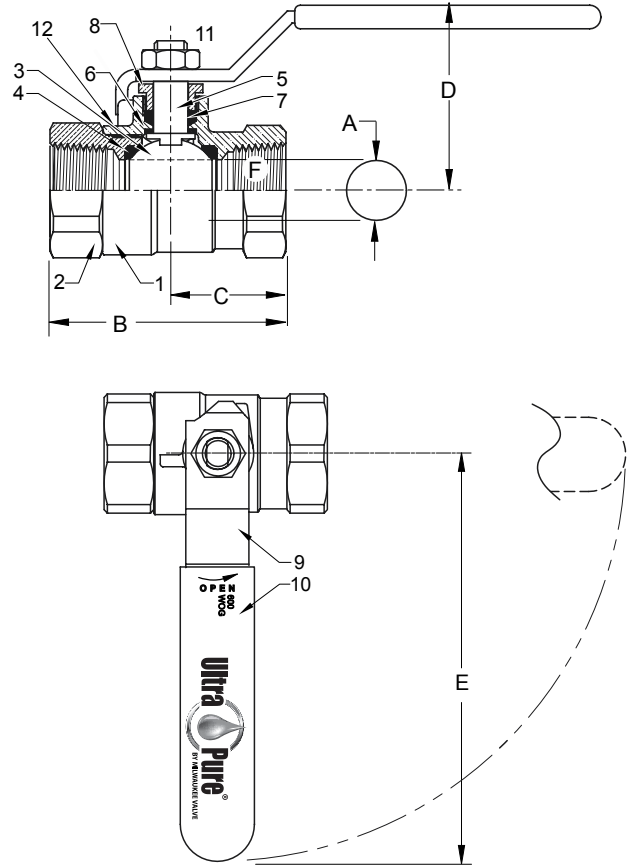

DIMENSIONS

	UNITS	1/4" DN6	3/8" DN10	1/2" DN15	3/4" DN20	1" DN25	1-1/4" DN32	1-1/2" DN40	2" DN50	2-1/2" DN65	3" DN80
A (DIA)	INCHES	0.38	0.38	0.50	0.76	0.88	1.06	1.31	1.56	2.00	2.31
	mm	10	10	13	19	22	27	33	40	51	59
B	INCHES	1.86	1.86	2.19	2.59	3.17	3.50	3.96	4.30	5.58	6.17
	mm	46	46	54	66	78	86	97	105	142	157
C	INCHES	1.00	1.00	1.10	1.30	1.58	1.74	1.97	2.15	2.79	3.10
	mm	25	25	27	32	39	43	48	53	71	79
D	INCHES	1.78	1.81	1.91	2.08	2.25	2.66	2.84	3.00	3.44	3.84
	mm	44	44	47	51	55	65	70	74	87	98
E	INCHES	3.81	3.81	3.81	4.56	4.56	6.31	6.31	7.19	7.19	7.19
	mm	93	93	93	112	112	155	155	176	176	176
F	THREAD SIZE	1/4" NPT	3/8" NPT	1/2" NPT	3/4" NPT	1" NPT	1-1/4" NPT	1-1/2" NPT	2" NPT	2-1/2" NPT	3" NPT
Cv		7	7	13	30	38	61	87	121	228	305

Note: DN (Diameter Nominal) = Metric equivalent size.

*2-1/2" & 3" Only.

Note: Lead free refers to the wetted surface of the pipe, fittings and fixtures in potable water systems that have a weighted average lead content $\leq 0.25\%$. Source: California Health and Safety Code (116875).

The information presented on this sheet is correct at time of publication. Milwaukee Valve reserves the right to change design and/or materials without notice. For our Installation, Operation and Maintenance Manual and the most current product information go to www.milwaukeevalve.com.

⚠ State of California Prop 65 **WARNING:** Cancer and Reproductive Harm. For more information visit www.p65warnings.ca.gov.

