

# F-2882-M 14"-24"

**Iron Gate Valve**  
**100 SWP - 150 WOG †**  
**Non-Rising Stem • Solid Wedge Disc**  
**Bolted Bonnet • Flanged Ends**  
**Conforms to: MSS SP-70**

Flange shape and drilling to specification ASME B 16.1 (125 lb.)

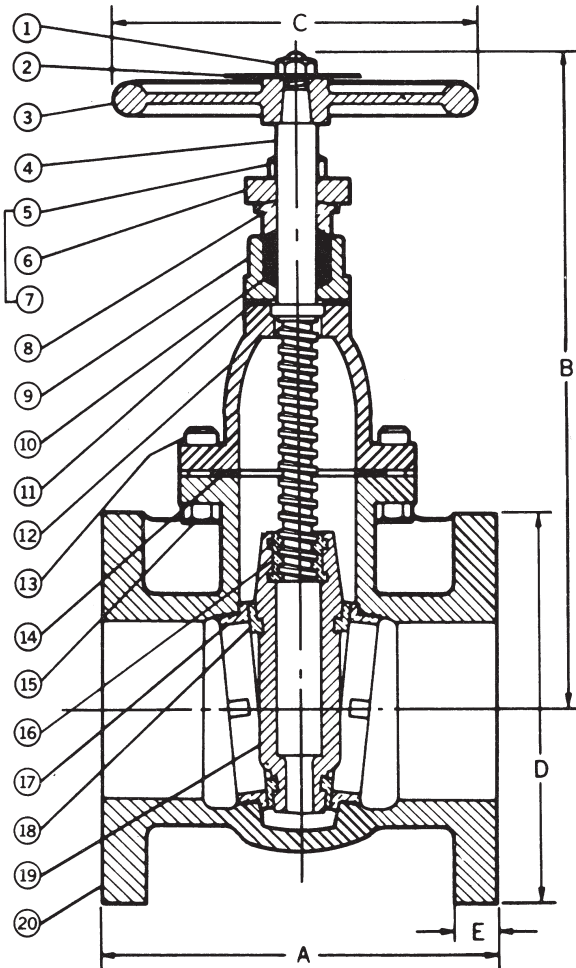

MATERIAL LIST			
No.	PART	MATERIAL	SPECIFICATION
1	Handwheel Nut	Steel	ASTM A307
2	Name Plate	Aluminum	
3	Handwheel	Cast Iron	ASTM A126, Class B
4	Stem	Brass	ASTM B16
5	Gland Follower Nut	Steel	ASTM A307
6	Gland Follower	Ductile Iron	ASTM A536
7	Gland Follower Bolt	Steel	ASTM A307
8	Packing Gland	Cast Bronze	ASTM B62
9	Stuffing Box	Cast Iron	ASTM A126, Class B
10	Packing	Graphite	
11	Stuffing Box Gasket	Non-Asbestos	
12	Bonnet	Cast Iron	ASTM A126, Class B
13	Body Bolt	Steel	ASTM A307
14	Body Gasket	Graphite	
15	Body Nut	Steel	ASTM A307
16	Wedge Bushing	Bronze	ASTM B62
17	Seat Ring	Bronze	ASTM B62
18	Wedge Face Ring	Bronze	ASTM B62
19	Wedge	Cast Iron	ASTM A126, Class B
20	Body	Cast Iron	ASTM A126, Class B
21	Stuffing Box Nut (not shown)	Steel	ASTM A563-B

DIMENSIONS - INCHES/MILLIMETERS							
Units	Size	A	B	C	D	E	C <sub>v</sub>
Inches	14	15.00	39.50	20.00	21.00	1.38	13800
mm		381	1003	508	533	35	
Inches	16	16.00	43.30	22.00	23.50	1.44	18375
mm		406	1100	559	597	37	
Inches	18	17.00	47.62	24.00	25.00	1.56	23600
mm		432	1210	610	635	40	
Inches	20	18.00	54.38	24.00	27.50	1.69	29600
mm		457	1381	610	699	43	
Inches	24	20.00	58.25	30.00	32.00	1.88	43570
mm		610	1480	762	813	48	

Suffix M – Signifies “MILVACO” Series International Valves.  
 † Non-Shock



The information presented on this sheet is correct at time of publication. Milwaukee Valve reserves the right to change design and/or materials without notice. For our Installation, Operation and Maintenance Manual and the most current product information go to [www.milwaukeevalve.com](http://www.milwaukeevalve.com).  State of California Prop 65  
**WARNING:** Cancer and Reproductive Harm. For more information visit [www.p65warnings.ca.gov](http://www.p65warnings.ca.gov).

