

TIHL INSTALLATION & OPERATION INSTRUCTIONS

1. Cycle valve clockwise to close position.
2. Remove valve handle nut and handle, note orientation of handle stops.
Set handle nut aside for later use.
3. Remove handle cap, set aside.
4. Loosen and remove the (2) handle button head SCS using a 1/8" Allen wrench, set aside.
5. Remove memory stop assembly, set aside
6. Remove the handle sleeve, set aside.
7. Mount handle housing to valve stem (ensure handle shield is placed around handle housing), orientate stop position the same as handle was in step 2.
8. Secure handle housing to the valve stem using handle nut from step 2 to hold housing in place. If assembling the large size handle ("J" size) place the included washer on the valve stem, then secure housing to the valve with the nut.
9. Insert handle sleeve into the housing ensuring the engagement plate fork goes over the open stop (Photo A). Also ensure that the insulation insert is inside of the sleeve.



(Photo

10. Place the memory stop assembly onto the sleeve ensuring the pad lock holes line up on both pieces (Photo B). Secure the memory stop assembly with the (2) button head screws from step 4 (Photo C).

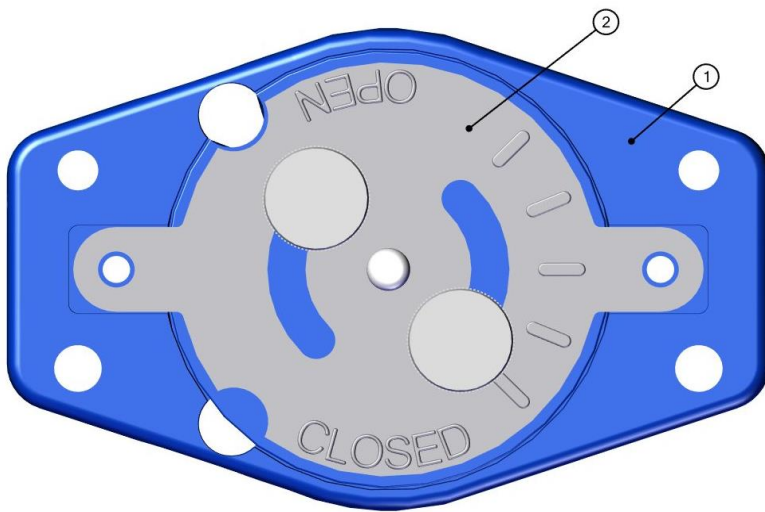

(Photo B)



(Photo C)

11. Setting memory stop if required. If not skip to step 12.
- 11a. The TIHL comes equipped with a toolless memory stop which is set while the valve is in the closed position or in the desired throttling position, as indicated by the (5) raised indications on the plate, under the red cover.
- 11b. With the valve in the closed position or partial opened position, remove the cover and loosen the thumb screws, do not remove these thumb screws completely. If the valve is in the closed position align the thumb screws in the slots with the desired throttling position and tighten them down. If the valve is already set to the desired throttling position, align the thumb screws in the slots until they stop and tighten them down.

Always replace the red cap after setting the memory stop position.

11c. With the memory stop set, operators will now be able to close the valve and open it again to the set throttling position. Operators will not be able to fully open the valve without first loosening the thumb screws. Operators will also not be able to lock the valve in the throttling position as the handle can only be locked with the valve in the open or closed position.

The Valve should not be left in the memory stop position for extended periods of time, as this can damage the sealing elements.

12. Replace handle cap by aligning the pegs on the cap to the holes on the handle. The Cover can only be secured one way as the peg and hole size correlate (Photo D).

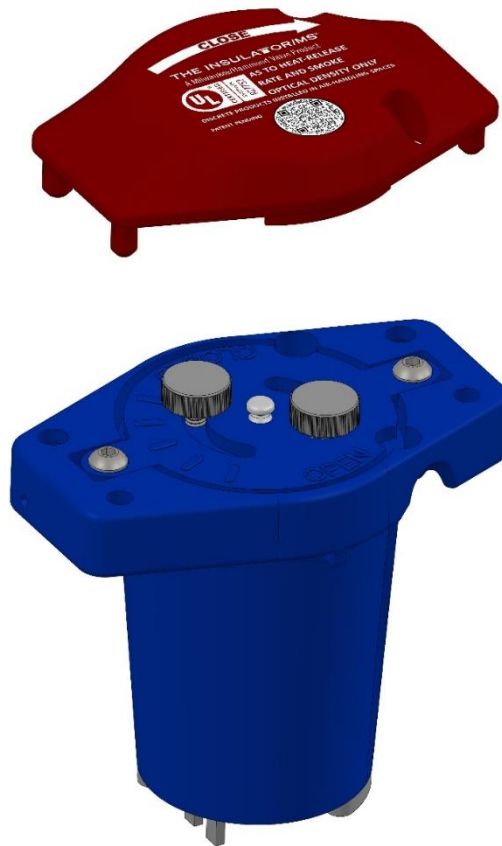

(Photo D)

13. If the valve is in the open or closed position, a lock can be put through either the open or closed locking hole respectively. This feature is for lockout/tagout purposes and to ensure the valve can't be rotated by an unauthorized individual. The handle is designed for the lock to enter the hole from the bottom with the face plate facing the operator (Photo E). Most locks can still be used from the top.



(Photo E)

14. A clear plastic insulation shield is provided with all TIHL Valves. This will preserve the functionality of the handle mechanism if spray foam or cloth insulation is required for a given application.