

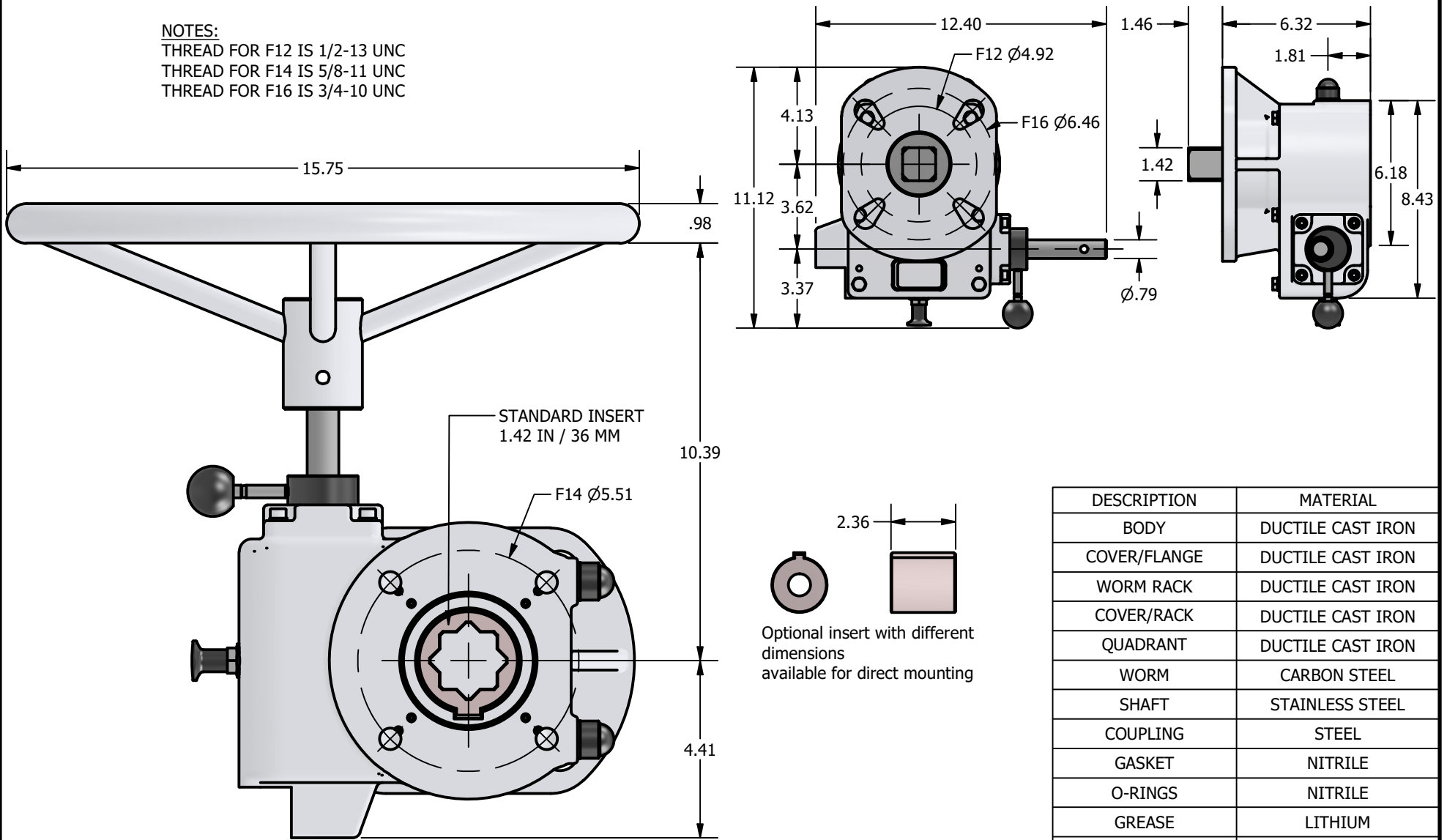

NOTES:
 THREAD FOR F12 IS 1/2-13 UNC
 THREAD FOR F14 IS 5/8-11 UNC
 THREAD FOR F16 IS 3/4-10 UNC



DESCRIPTION	MATERIAL
BODY	DUCTILE CAST IRON
COVER/FLANGE	DUCTILE CAST IRON
WORM RACK	DUCTILE CAST IRON
COVER/RACK	DUCTILE CAST IRON
QUADRANT	DUCTILE CAST IRON
WORM	CARBON STEEL
SHAFT	STAINLESS STEEL
COUPLING	STEEL
GASKET	NITRILE
O-RINGS	NITRILE
GREASE	LITHIUM
FASTENERS	STAINLESS STEEL
AXIAL BEARING	STEEL

DESCRIPTION Quarter Turn Type: UT-ZM-177				NOTICE: THIS DRAWING INCLUDES THE DESIGN AND PRINCIPLES DISCLOSED AND IS THE SOLE PROPERTY OF UNITORQ AND ITS AFFILIATES. IT IS NOT TO BE REPRODUCED, NOR COPIED IN WHOLE OR IN PART, NOR LOANED OR OTHERWISE COMMUNICATED TO ANY THIRD PARTY, NOR USED IN ANY MANNER DETRIMENTAL TO THE INTERESTS OF UNITORQ OR ANY OF ITS AFFILIATES WITHOUT THE EXPRESSED WRITTEN CONSENT OF UNITORQ. ACCEPTANCE OF THIS DRAWING WILL BE CONSTRUED AS AN AGREEMENT TO THE ABOVE.				2150 Boggs Road, Suite 410 DULUTH, GEORGIA U.S.A. 30096 Ph: 770-446-7074 Fax: 770-447-1825 www.unitorq.com		
TYPE UT-ZM-177	TORQUE (In-Lbs) 17,702	RATIO 1:43	WEIGHT (lbs) 55.12	PRODUCT: Quarter Turn Actuator	PART NUMBER: UT-ZM-177	SALES DRAWING NUMBER:	DWN BY: HP	DATE: 1/25/2024	SCALE: N.T.S	REV. 0

