



# UPBA100SH/UPBA150SH 1/2" & 3/4"

Bronze Ball Valve For Potable Water

Two Piece

Full Port

600 WOG

Threaded x 3/4" Hose End (UPBA100SH)

Solder x 3/4" Hose End (UPBA150SH)

Dust Cap and Chain

Blow-Out Proof Stem

Dimensions and Workmanship Conform to MSS SP-110



Tested and Certified by IAPMO R&T to NSF/ANSI 61 and NSF/ANSI 372 for lead free compliance.

## MATERIAL LIST

ITEM	PART	MATERIALS	ASTM SPEC.
1	Body	Cast Bronze	B584 C89833
2	Tailpiece	Brass	B283 C27450
3	Ball	316 Stainless Steel	A276
4	Seat	PTFE (1/2") RPTFE, 25% Glass Filled (3/4")	Commercial
5	Stem	316 Stainless Steel	A276
6	Thrust Washer	RPTFE, 25% Glass Filled	Commercial
7	Packing	PTFE	Commercial
8	Packing Nut	Brass	B16 C36000
9	Handle	Steel, Zinc Plated	Commercial
10	Handle Grip	Vinyl	Commercial
11	Handle Nut	Steel, Zinc Plated	Commercial
12	Dust Cap	Polypropylene	Commercial
13	Gasket	EDPM	Commercial
14	Chain	Brass Bead	Commercial

**Do not pressurize cap.  
Pressure not to exceed 40 psi.**

**Note:** Pressure/Temperature rating shown are for VALVE ONLY. Hose side pressure and temperature limit is based on connected hose and is users responsibility

## DIMENSIONS

	UNITS	1/2" DN15	3/4" DN20
ØA	INCHES	0.50	0.76
	mm	13	19
B (BA-100)	INCHES	2.70	2.90
	mm	69	74
B' (BA-150)	INCHES	2.55	3.05
	mm	65	78
C (BA-100)	INCHES	1.10	1.30
	mm	28	33
C' (BA-150)	INCHES	1.10	1.45
	mm	28	37
D	INCHES	1.88	2.14
	mm	48	54
E	INCHES	3.81	4.62
	mm	97	117
F	THREADED INLET	NPT	NPT
Cv		13	30

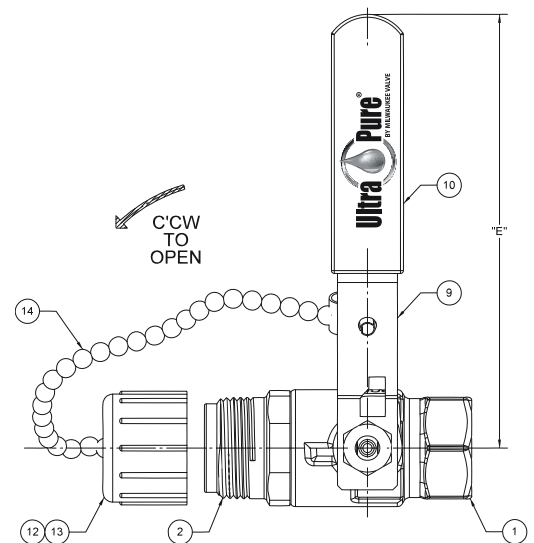
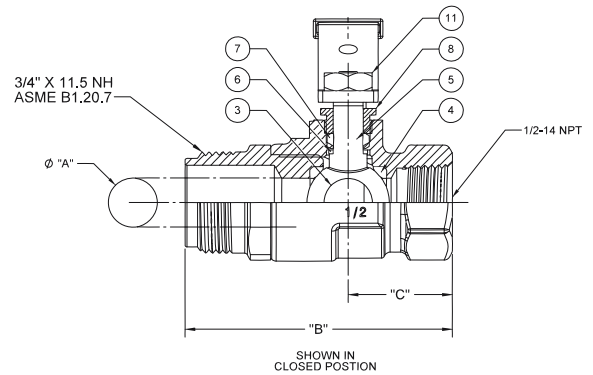
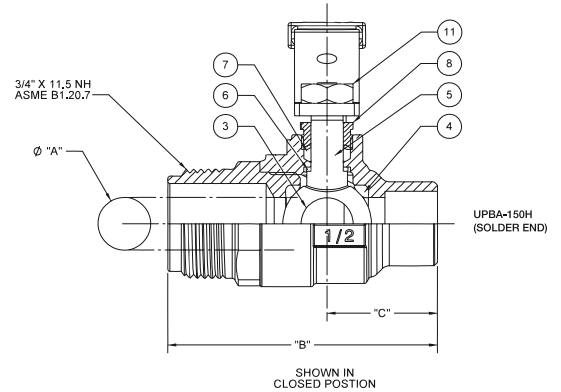

The information presented on this sheet is correct at time of publication. Milwaukee Valve reserves the right to change design and/or materials without notice. For our Installation, Operation and Maintenance Manual and the most current product information go to [www.milwaukeevalve.com](http://www.milwaukeevalve.com).

⚠ State of California Prop 65 **WARNING:** Cancer and Reproductive Harm. For more information visit [www.p65warnings.ca.gov](http://www.p65warnings.ca.gov).

